

Design

The steel ball valves are designed manufactured to provide maximum service life and dependability. All ball valves are full ported and meet the design requirements of American Petroleum Institute Standard API 608&API 6D British standard BS5351 and generally conform to American Society of Mechanical engineers standard ASME B16.34 valves are available in a complete range of body/bonnet materials and trims.

Available Modifications

- Trim changes
- End connection modifications
- Packing and gasket change
- Operator mounting
- Handwheel extensions

Ranges of Materials

Standard body/bonnet materials include nine grades of carbon, low alloy and stainless steel, for special applications they can be supplied in other grades of alloy and stainless steel. There's a full range of trim materials to match any service optional packing and gasket materials are available for a full range of service conditions.

- Pressure equalizing
- As or fd
- Customer specified coatings
- Weld end bore changes
- Oxygen&chlorine cleaning&packaging

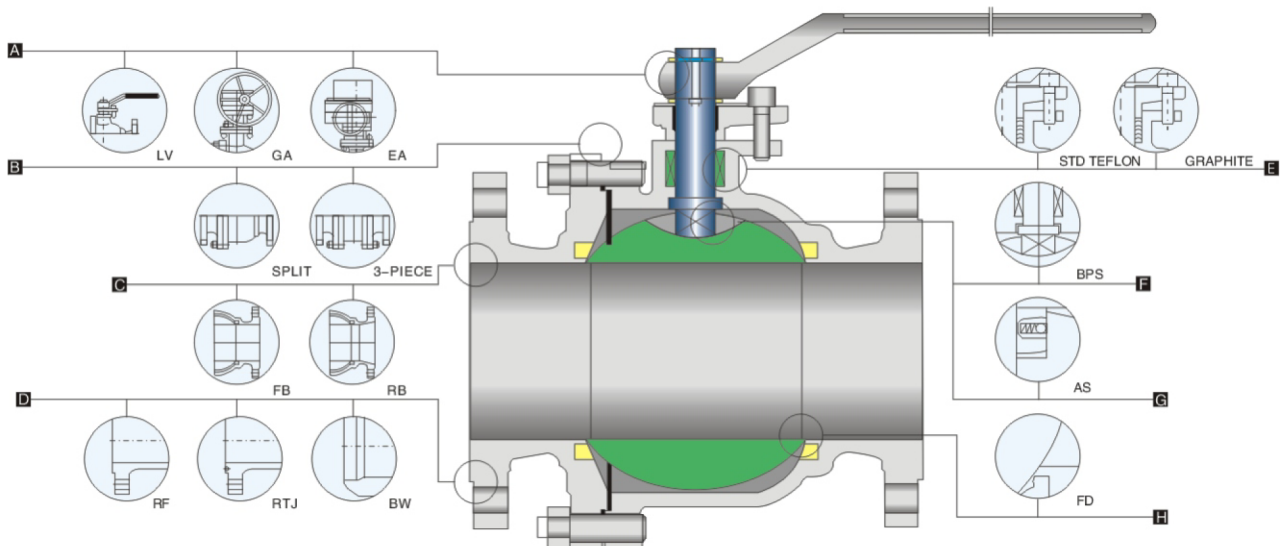

A Operation

Extended lever for easy operation. also available with gearing, motor actuators, pneumatic or hydraulic actuators for more difficult services

B Body&Bonnet

Split or 3-piece, split body & bonnet for 12" & small. disassembles easily for repair components.

C BORE

Full bore or reduced bore. full-bore design provides exceptional flow control.

D End Connections

A choice of flanged RTJ flanged or butt welding end for piping flexibility.

E Packing

Std packing multiple v-teflon packing, combined with live loading, maintains packing compression under high-cycle and severe service applications. Graphite packing is used for high-temperature situation.

F BPS

Blow-out proof stem
A pressure-safe stem shoulder design that protects against failure under excess pressure.

G AS

Anti statics. A metallic contact is always granted between ball and stem /body to discharge eventual statics build-up during service.

H FS

Fire safe designed to API 607 or BS 6755 to grant their operation suitability in case of fire. Secondary metal-to-metal seal acts as backup if primary seal is destroyed by fire. Valves ordered for compliance with API 607 will be provided with graphite packing and gaskets.

Applicable Standards:

- STEEL BALL VALVES API 608/API 6D
- STEEL BALL VALVES ISO 14313
- FIRE SAFE, API 607
- ANTI STATIC, API 608
- STEEL VALVES, ASME B16.34
- FACE TO FACE ASME B16.10
- END FLANGES, ASME B16.5
- BUTTWELDING ENDS ASME B16.25
- INSPECTION AND TEST, API 598/ API 6D

Design descriptions:

- FULL PORT DESIGN
- BG.BOLTED BONNET.SPLIT BODY
- FLOATING BALL TYPE
- BLOW-OUT PROOF STEM
- FIRE DURABLE CONSTRUCTION
- ANTI STATIC DEVICE
- STOPPER DEVICE
- ISO 5211 MOUNTING PAD
- FLANGED OR BUTTWELDING ENDS
- AVAILABLE WITH WG OPERATOR

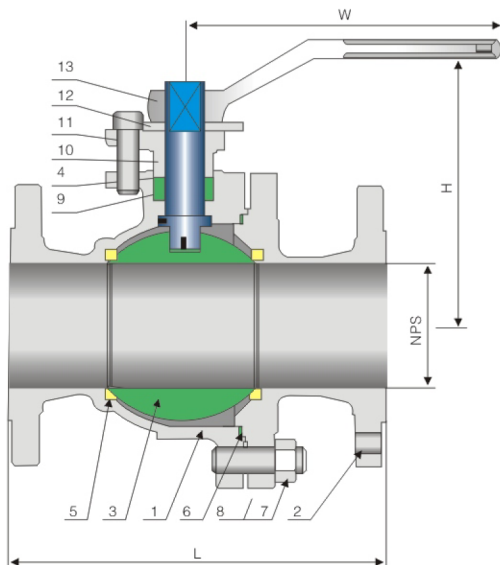

Materials of Parts

No	Part Name	Carbon Steel	ASTM Materials 18Cr-9Ni-2Mo	Carbon Steel
1	Body	A216-WCB	A351-CF8M	A352-LCB
2	Bonnet	A216-WCB	A351-CF8M	A352-LCB
3	Ball	A182-F304 ¹⁾	A182-F316	A182-F304 ¹⁾
4	Stem	A276-304	A276-316	A276-304
5	Seat Ring	R.PTFE		
6	Bonnet Gasket	Graphite+304 ²⁾	PTFE	Graphite+304 ²⁾
7	Bonnet stud	A193-B7	A193-B8	A320-L7
8	Bonnet Stud Nut	A194-2H	A194-8	A194-4
9	Packing	PTFE		
10	Gland Flange	A216-WCB	A351-CF8M	A352-LCB
11	Gland Bolt	A193-B7	A193-B8	A193-B7
12	Stop Plate	Carbon Steel	Carbon steel+Zn	Carbon Steel
13	Handle	Carbon Steel		

Note:1)A105+ENP optional
2)Spiral wound construction.

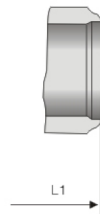

Dimensional datas of ANSI Class 150Lb

NPS DN	1/2 15	3/4 20	1 25	1 1/2 40	2 50	2 1/2 65	3 80	4 100	6 150	8 200	10 250	12 300	in mm
L (RF)	4.25 108	4.62 117	5.00 127	6.50 165	7.00 178	7.50 190	8.00 203	9.00 229	15.50 394	18.00 457	21.00 533	24.00 610	in mm
L1 (BW)	5.50 140	6.00 152	6.50 165	7.50 190	8.50 216	9.50 241	11.12 283	12.00 305	18.00 457	20.50 521	22.00 559	25.00 635	in mm
H	2.12 55	2.12 55	2.75 70	3.50 90	4.12 105	6.12 155	7.25 185	8.00 205	10.00 255	11.00 280	13.50 345	16.50 420	in mm
W	5 130	5 130	6 160	8 200	14 350	16 400	20 500	20 500	24 600	32 800	32 800	32 800	in mm
wt(kg)	2.3 1.8	3 2.8	4.5 3.7	7 6.2	9.5 8.5	15 14	19 21	33 35	93 98	160 170	200 225	280 295	RF BW

Applicable Standards:

- STEEL BALL VALVES API 608/API 6D
- STEEL BALL VALVES ISO 14313
- FIRE SAFE, API 607
- ANTI STATIC, API 608
- STEEL VALVES, ASME B16.34
- FACE TO FACE ASME B16.10
- END FLANGES, ASME B16.5
- BUTTWELDING ENDS ASME B16.25
- INSPECTION AND TEST, API 598/ API 6D

Design descriptions:

- FULL PORT DESIGN
- BG.BOLTED BONNET.SPLIT BODY
- FLOATING BALL TYPE
- BLOW-OUT PROOF STEM
- FIRE DURABLE CONSTRUCTION
- ANTI STATIC DEVICE
- STOPPER DEVICE
- ISO 5211 MOUNTING PAD
- FLANGED OR BUTTWELDING ENDS
- AVAILABLE WITH WG OPERATOR

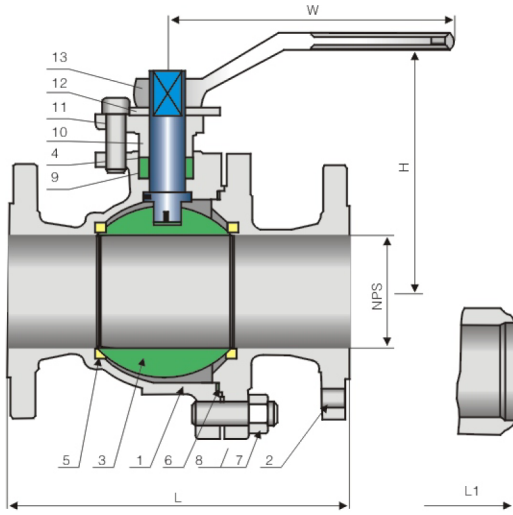

Materials of Parts

No	Part Name	Carbon Steel	ASTM Materials 18Cr-9Ni-2Mo	Carbon Steel
1	Body	A216-WCB	A351-CF8M	A352-LCB
2	Bonnet	A216-WCB	A351-CF8M	A352-LCB
3	Ball	A182-F304 ¹⁾	A182-F316	A182-F304 ¹⁾
4	Stem	A276-304	A276-316	A276-304
5	Seat Ring	R.PTFE		
6	Bonnet Gasket	Graphite+304 ²⁾	PTFE	Graphite+304 ²⁾
7	Bonnet stud	A193-B7	A193-B8	A320-L7
8	Bonnet Stud Nut	A194-2H	A194-8	A194-4
9	Packing	PTFE		
10	Gland Flange	A216-WCB	A351-CF8M	A352-LCB
11	Gland Bolt	A193-B7	A193-B8	A193-B7
12	Stop Plate	Carbon Steel	Carbon steel+Zn	Carbon Steel
13	Handle	Carbon Steel		

Note:1)A105+ENP optional
2)Spiral wound construction.

Dimensional datas of ANSI Class 300Lb

NPS DN	1/2 15	3/4 20	1 25	1 1/2 40	2 50	2 1/2 65	3 80	4 100	6 150	8 200	10 250	12 300	in mm
L (RF)	5.50 140	6.00 152	6.50 165	7.50 190	8.50 216	9.50 241	11.12 283	12.00 305	15.88 403	19.75 502	22.38 568	25.50 648	in mm
L1 (BW)	5.50 140	6.00 152	6.50 165	7.50 190	8.50 216	9.50 241	11.12 283	12.00 305	18.00 457	20.50 521	22.00 559	25.00 635	in mm
H	2.12 55	2.12 55	2.75 70	3.50 90	4.12 105	6.12 153	7.25 187	8.00 206	10.00 255	11.00 280	13.50 345	16.50 420	in mm
W	5 130	5 130	6 160	8 200	14 350	16 400	20 500	20 500	24 600	32 800	32 800	32 800	in mm
wt(kg)	2.5 1.8	3.5 2	5.5 3.2	10.5 5.5	14.5 8.7	23.5 15	30 18	55 36	118 85	200 152	250 182	330 232	RF BW

Dimensional datas of ANSI Class 600Lb

NPS DN	1/2 15	3/4 20	1 25	1 1/2 40	2 50	2 1/2 65	3 80	4 100	6 150	8 200	10 250	12 300	in mm
L/L1 (RF/BW)	6.50 165	7.50 190	8.50 216	9.50 241	11.50 292	13.00 330	14.00 356	17.00 432	22.00 559	-	-	-	in mm
L2 (RTJ)	-	-	-	-	11.62 295	13.12 333	14.12 359	17.12 435	22.12 562	-	-	-	in mm
H	2.38 61.5	2.38 61.5	3.00 78	4.00 101	4.75 120	6.88 174	8.38 212	9.25 234	11.38 289	-	-	-	in mm
W	5 130	6 160	8 200	14 350	16 400	20 500	24 600	24 600	32 800	-	-	-	in mm
wt(kg)	3.3 2.6	4.5 3.1	7.2 4.8	13.5 8	19 3	31 22	39 27	71 53	153 120	-	-	-	RF/RTJ BW

Design

The steel ball valves are designed manufactured to provide maximum service life and dependability. All ball valves are full ported and meet the design requirements of American Petroleum Institute standard API 608&API 6D British standard BS 5351 and generally conform to American society of Mechanical Engineers standard ASME B16.34 valves are available in a complete range of body/bonnet materials and trims.

Available Modifications

Trim Changes
 End Connection Modifications
 Packing And Gasket Change
 Operator Mounting
 Handwheel Extensions

Ranges of Materials

Standard body/bonnet materials include nine grades of carbon, low alloy and stainless steel, for special applications they can be supplied in other grades of ally and stainless steel, there's a full range of trim materials to match any service optional packing and gasket materials are available for a full range of service conditions.

Pressure Equalizing
 AS OR FD
 Customer Specified Coatings
 Weld End Bore Changes
 Oxygen & Chlorine Cleaning & Packaging

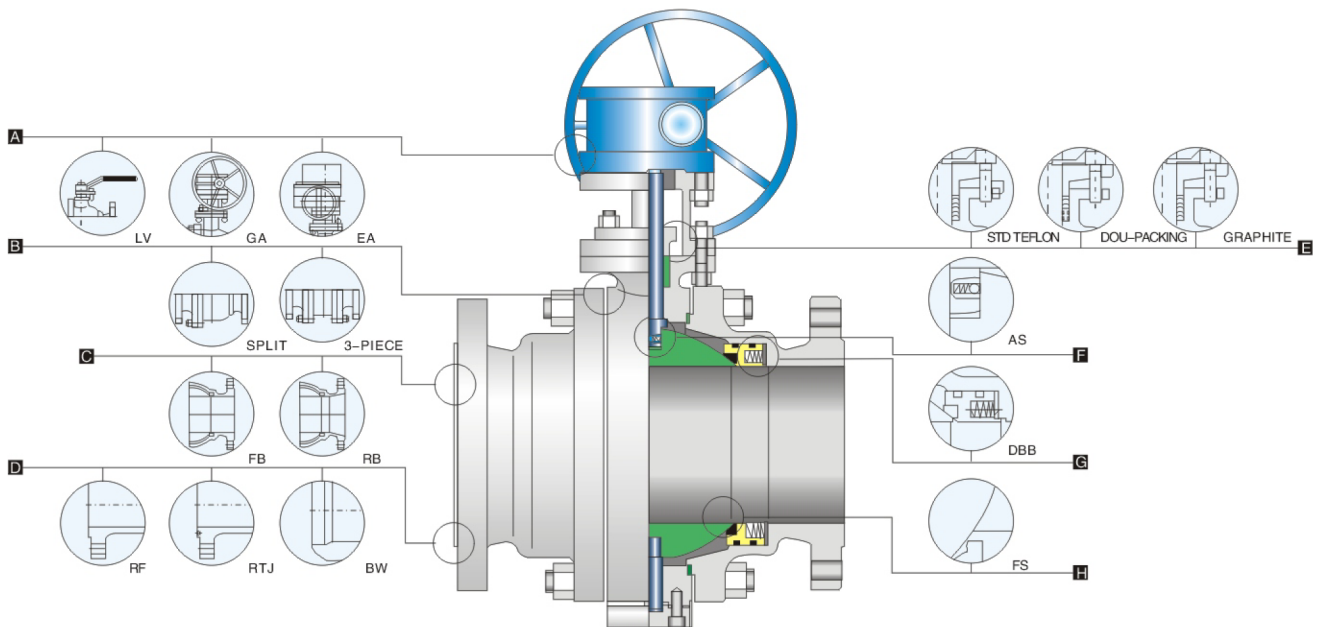

A Operation

Extended lever for easy operation. Also available with gearing, motor actuators, pneumatic or hydraulic actuators for more difficult services

B Body&bonnet

Split or 3-piece, split body & bonnet for 12" & small. Disassembles easily for repair or replacement of internal components.

C BORE

Full bore or reduced bore. Full-bore design provides exceptional flow control.

D End Connections

A choice of flanged RTJ flanged or buttwelding end for piping flexibility.

E Packing

Std packing multiple v-teflon packing, combined with live loading, maintains packing compression under high-cycle and severe service applications. Graphite packing is used for high-temperature situation.

F AS

Anti statics. A metallic contact is always granted between ball and stem/body to discharge eventual statics build-up during service.

G DBB

Double block & bleed. The body cavity is isolated when the ball is in either fully closed or fully opened position, the medium entrapped in it can easily be bled to avoid over pressure.

H FS

Fire safe designed to API 607 or BS 6755 to grant their operation suitability in case of fire. Secondary metal-to metal seal acts as backup if primary seal is destroyed by fire. Valves ordered for compliance with API 607 will be provided with graphite packing and gaskets.

Applicable Standards:

- STEEL BALL VALVES API 608/API 6D
- STEEL BALL VALVES ISO 14313
- FIRE SAFE, API 607
- ANTI STATICS, API 608
- STEEL VALVES, ASME B16.34
- FACE TO FACE ASME B16.10
- END FLANGES, ASME B16.5
- BUTTWELDING ENDS ASME B16.25
- INSPECTION AND TEST, API 598/ API 6D

Design descriptions:

- FULL PORT DESIGN
- BB.BOLTED BONNET.SPLIT BODY
- THREE PIECES BODY FOR 12" & ABOVE
- TRUNNION MOUNTED BALL TYPE
- BLOW-OUT PROOF STEM
- FIRE SAFE CONSTRUCTION
- ANTI STATICS DEVICE
- STOPPER DEVICE
- ISO 5211 MOUNTING PAD
- FLANGED OR BUTTWELDING ENDS
- AVAILABLE WITH WG OPERATOR

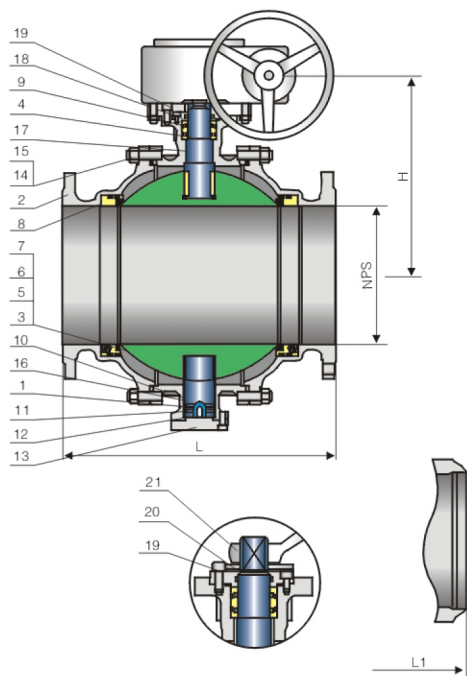

Materials of parts

No	Part Name	Carbon Steel	ASTM Materials 18Cr-9Ni-2Mo	Carbon Steel
1	Body	A216-WCB	A351-CF8M	A352-LCB
2	Bonnet	A216-WCB	A351-CF8M	A352-LCB
3	Ball	A182-F304 ¹⁾	A182-F316	A182-F304 ¹⁾
4	Stem	A276-304	A276-316	A276-304
5	Seat	A105+ENP	A182-F316	A350-LF2+ENP
6	Seat Insert	Glass Filled PTFE		
7	Seat Spring	A313-304	Inconel X-750	A313-304
8	Seat O-Ring	NPR	Viton	Viton
9	Stem O-Ring	NBR	Viton	Viton
10	Bonnet Gasket	Graphite+304 ²⁾	Graphite+316 ²⁾	Graphite+304 ²⁾
11	Bonnet O-Ring	NBR	Viton	Viton
12	Antistatic Spring	A313-304	A313-316	A313-304
13	Lower Cover	A216-WCB	A182-F316	A182-F304
14	Bonnet Stud	A193-B7	A193-B8	A320-L7
15	Bonnet Stud Nut	A194-2H	A194-8	A194-4
16	Trunnion	A276-304	A276-316	A276-304
17	Trunnion Bearing	304+PTFE	316+PTFE	304+PTFE
18	Gland Flange	A216-WCB	A351-CF8M	A352-LCB
19	Gland Bolt	A193-B7	A193-B8	A193-B7
20	Stop Plate	Carbon Steel	Carbon Steel+Zn	Carbon Steel
21	Handle	Carbon Steel		

Note: 1)A105+ENP optional
2)Spiral wound construction.

Dimensional datas of ANSI Class 150Lb

NPS DN	2 50	2 1/2 65	3 80	4 100	6 150	8 200	10 250	12 300	14 350	16 400	18 450	20 500	24 600	26 650	28 700	30 750	32 800	36 900	in mm
L (RF)	7.00	7.50	8.00	9.00	15.50	18.00	21.00	24.00	27.00	30.00	34.00	36.00	42.00	45.00	49.00	51.00	54.00	60.00	in
	178	190	203	229	394	457	533	610	686	762	864	914	1067	1143	1245	1295	1372	1524	mm
L1 (BW)	8.50	9.50	11.12	12.00	18.00	20.50	22.00	25.00	30.00	33.00	36.00	39.00	45.00	49.00	53.00	55.00	60.00	68.00	in
	216	241	283	305	457	521	559	635	762	838	914	991	1143	1245	1346	1397	1524	1727	mm
H	7.00	7.50	8.25	9.25	20.88	24.62	25.62	30.75	31.00	36.25	38.25	43.38	45.25	50.75	55.12	64.12	70.88	80.75	in
	177	190	210	235	530	625	650	780	790	920	970	1100	1150	1290	1400	1630	1840	2050	mm
W	14	16	20	20	24	24	24	24	32	32	32	32	32	32	32	32	32	32	in
	350	400	500	500	600	600	600	600	800	800	800	800	800	800	800	800	800	800	mm
wt(kg)	15	19	27	38	81	140	160	205	260	390	510	750	1200	1400	1860	2100	2530	2970	RF
	13.5	15.5	24.5	32.5	76	132	147	182	241	370	495	726	1125	1250	1640	1930	2390	2760	BW

Dimensional datas of ANSI Class 300Lb

NPS DN	2 50	2 1/2 65	3 80	4 100	6 150	8 200	10 250	12 300	14 350	16 400	18 450	20 500	24 600	26 650	28 700	30 750	32 800	36 900	in mm
L (RF)	8.50	9.50	11.12	12.00	15.88	19.75	22.38	25.50	30.00	33.00	36.00	39.00	45.00	49.00	53.00	55.00	60.00	-	in
	216	241	283	305	403	502	568	648	762	838	914	991	1143	1245	1346	1397	1524	-	mm
L1 (BW)	8.50	9.50	11.12	12.00	18.00	20.50	22.00	25.00	30.00	33.00	36.00	39.00	45.00	49.00	53.00	55.00	60.00	-	in
	216	241	283	305	403	521	559	635	762	838	914	991	1143	1245	1346	1397	1524	-	mm
H	7.00	7.50	8.25	9.25	20.88	24.62	25.62	30.75	31.00	36.25	38.25	43.38	45.25	50.75	55.12	64.12	70.88	-	in
	177	190	210	235	530	625	650	780	790	920	970	1100	1150	1290	1400	1630	1800	-	mm
W	14	16	20	20	24	24	24	24	32	32	32	32	32	32	32	32	32	-	in
	350	400	500	500	600	600	600	600	800	800	800	800	800	800	800	800	800	-	mm
wt(kg)	19	24	34	48	101	175	200	255	325	485	635	935	1500	1750	2225	2450	2870	-	RF
	14	16	25	34	82	145	155	185	238	375	516	782	1280	1375	1825	2180	2260	-	BW

Applicable Standards:

- STEEL BALL VALVES API 608/API 6D
- STEEL BALL VALVES ISO 14313
- FIRE SAFE, API 607
- ANTI STATICS, API 608
- STEEL VALVES, ASME B16.34
- FACE TO FACE ASME B16.10
- END FLANGES, ASME B16.5
- BUTTWELDING ENDS ASME B16.25
- INSPECTION AND TEST, API 598/ API 6D

Design descriptions:

- FULL PORT DESIGN
- BB.BOLTED BONNET.SPLIT BODY
- THREE PIECES BODY FOR 12" & ABOVE
- TRUNNION MOUNTED BALL TYPE
- BLOW-OUT PROOF STEM
- FIRE SAFE CONSTRUCTION
- ANTI STATICS DEVICE
- STOPPER DEVICE
- ISO 5211 MOUNTING PAD
- FLANGED OR BUTTWELDING ENDS
- AVAILABLE WITH WG OPERATOR

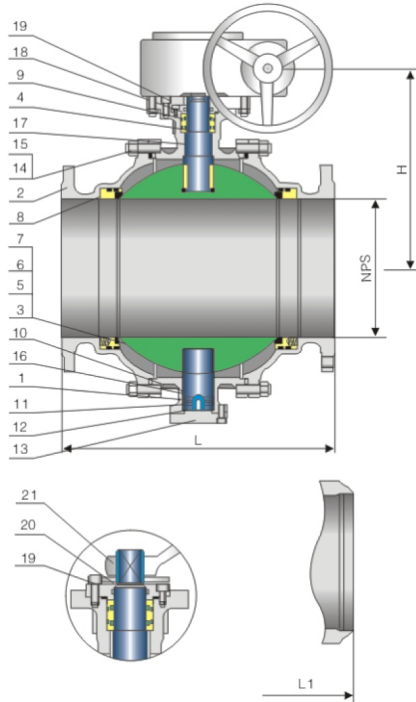

Materials of parts

No	Part Name	Carbon Steel	ASTM Materials 18Cr-9Ni-2Mo	Carbon Steel
1	Body	A216-WCB	A351-CF8M	A352-LCB
2	Bonnet	A216-WCB	A351-CF8M	A352-LCB
3	Ball	A182-F304 ¹⁾	A182-F316	A182-F304 ¹⁾
4	Stem	A276-304	A276-316	A276-304
5	Seat	A105+ENP	A182-F316	A350-LF2+ENP
6	Seat Insert	Glass Filled PTFE		
7	Seat Spring	A313-304	Inconel X-750	A313-304
8	Seat O-Ring	NPR	Viton	Viton
9	Stem O-Ring	NBR	Viton	Viton
10	Bonnet Gasket	Graphite+304 ²⁾	Graphite+316 ²⁾	Graphite+304 ²⁾
11	Bonnet O-Ring	NBR	Viton	Viton
12	Antistatic Spring	A313-304	A313-316	A313-304
13	Lower Cover	A216-WCB	A182-F316	A182-F304
14	Bonnet Stud	A193-B7	A193-B8	A320-L7
15	Bonnet Stud Nut	A194-2H	A194-8	A194-4
16	Trunnion	A276-304	A276-316	A276-304
17	Trunnion Bearing	304+PTFE	316+PTFE	304+PTFE
18	Gland Flange	A216-WCB	A351-CF8M	A352-LCB
19	Gland Bolt	A193-B7	A193-B8	A193-B7
20	Stop Plate	Carbon Steel	Carbon Steel+Zn	Carbon Steel
21	Handle	Carbon Steel		

Note: 1)A105+ENP optional
2)Spiral wound construction.

Dimensional datas of ANSI Class 600Lb

NPS DN	2 50	2 1/2 65	3 80	4 100	6 150	8 200	10 250	12 300	14 350	16 400	18 450	20 500	24 600	26 650	28 700	in mm
L/L1 (RF/BW)	11.50 292	13.00 330	14.00 356	17.00 432	22.00 559	26.00 660	31.00 787	33.00 838	35.00 889	39.00 991	43.00 1092	47.00 1194	55.00 1397	57.00 1448	61.00 1549	in mm
L2 (RTJ)	11.62 295	13.12 333	14.12 359	17.12 435	22.12 562	26.12 664	31.12 791	33.12 841	35.12 892	39.12 994	43.12 1095	47.25 1200	55.38 1407	57.50 1461	61.50 1562	in mm
H	7.12 180	7.62 193	8.50 215	9.50 241	21.25 540	25.00 635	26.12 665	31.12 790	31.88 810	36.38 925	38.75 985	44.50 1130	46.62 1185	52.50 1335	57.00 1450	in mm
W	14 350	16 400	20 500	20 500	24 600	24 600	24 600	24 600	32 800	32 800	32 800	32 800	32 800	32 800	32 800	in mm
wt(kg)	26 19	35 25	58 42	81 51	142 85	287 200	540 395	780 610	1000 805	1300 1010	1700 1350	2100 1656	3400 2775	3800 3125	4500 3790	RF/RTJ BW

Dimensional datas of ANSI Class 900Lb

NPS DN	2 50	2 1/2 65	3 80	4 100	6 150	8 200	10 250	12 300	14 350	16 400	18 450	20 500	24 600	in mm
L/L1 (RF/BW)	14.50 368	16.50 419	15.00 381	18.00 457	24.00 610	29.00 737	33.00 838	38.00 965	40.50 1029	44.50 1130	48.00 1219	52.00 1321	61.00 1549	in mm
L2 (RTJ)	14.62 371	16.62 422	15.12 384	18.12 460	24.12 613	29.12 740	33.12 841	38.12 968	40.88 1038	44.88 1140	48.50 1232	52.50 1334	61.75 1568	in mm
H	8.62 219	9.25 235	10.25 260	15.38 390	25.75 655	30.25 770	31.75 805	38.00 965	38.50 980	45.00 1145	47.00 1195	53.50 1360	56.00 1425	in mm
W	20 500	20 500	20 500	24 600	24 600	24 600	24 600	32 800	32 800	32 800	32 800	32 800	32 800	in mm
wt(kg)	31 23	43 31	68 51	98 61	171 102	345 240	650 480	940 735	1205 965	1565 1215	2050 1625	2535 1995	3950 3335	RF/RTJ BW

Design

The steel ball valves are designed and manufactured to provide maximum service life and dependability. All ball valves are full ported and meet the design requirements of American Petroleum Institute standard API 608&API 6D British standard BS 5351 and generally conform to American Society of Mechanical Engineers standard ASME B16.34 valves are available in a complete range of body/bonnet materials and trims.

Available Modifications

Trim changes
End connection modifications
Packing and gasket changes
Operator mounting
Handwheel extensions

Ranges of Materials

Standard body/bonnet materials include nine grades of carbon, low alloy and stainless steel, for special applications they can be supplied in other grades of alloy and stainless steel, there's a full range of trim materials to match any service optional packing and gasket materials are available for a full range of service conditions.

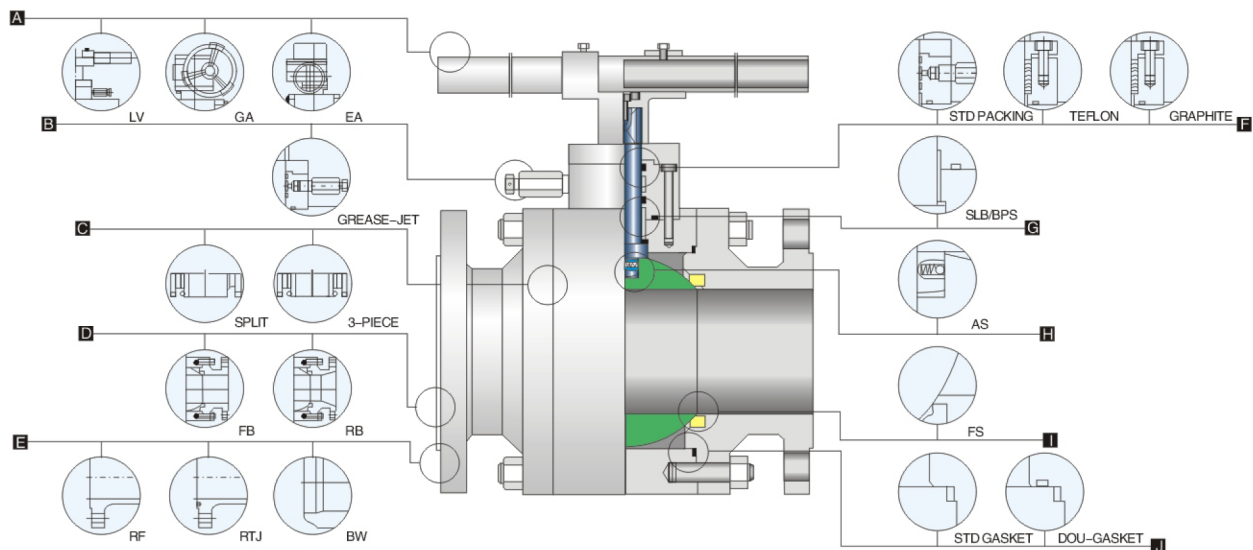

A Operation

Extended lever for easy operation. Also available with gearing, motor actuators, pneumatic or hydraulic actuators for more difficult services

B Grease-jet joint

Installed in prescriptive part accord to the apply and satisfied with ecumenical situations and realize seal in spot with maintenance easily.

C Body&Bonnet

Split or 3-piece, split body & bonnet for 8" & small. Disassembles easily for repair or replacement of internal components.

D BORE

Full bore or reduced bore. Full-bore design provides exceptional flow control.

E End Connectios

A choice of flanged RTJ flanged or buttwelding end for piping flexibility.

F Packing

Std packing multiple v-teflon packing, combined with live loading, maintains packing compression under high-cycle and severe service applications. Graphite packing is used for high-temperature situation.

G SLB

Self-lubrication bearing. Easy operation, low torque and longer life

BPS

Blow-out proof stem. A pressure-safe stem. Shoulder design that protects against failure under excess pressure.

H AS

Anti statics. A metallic contact is always granted between ball and stem/body to discharge eventual statics build-up during service.

I FS

Fire safe. designed to API 607 or BS 6755 to grant their operation suitability in case of fire. Secondary metal-to metal seal acts as back up if primary seal is destroyed by fire. Valves ordered for compliance with API 607 will be provided with graphite packing and gaskets.

J Gasket

Std gasket or dou-gasket. Std gasket adopt high-performance rubber seal ring. Dou-gasket adopt high-performance rubber seal ring and spiral wound graphite.

Applicable Standards:

- STEEL BALL VALVES API 608/API 6D
- STEEL BALL VALVES ISO 14313
- FIRE SAFE, API 607
- ANTI STATICS, API 608
- STEEL VALVES, ASME B16.34
- FACE TO FACE ASME B16.10
- END FLANGES, ASME B16.5
- BUTTWELDING ENDS ASME B16.25
- INSPECTION AND TEST, API 598/ API 6D

Design descriptions:

- FULL PORT DESIGN
- BB.BOLTED BONNET.SPLIT BODY
- FLOATING BALL TYPE
- BLOW-OUT PROOF STEM
- FIRE SAFE CONSTRUCTION
- ANTI STATICS DEVICE
- STOPPER DEVICE
- ISO 5211 MOUNTING PAD
- FLANGED OR BUTTWELDING ENDS
- AVAILABLE WITH WG OPERATOR

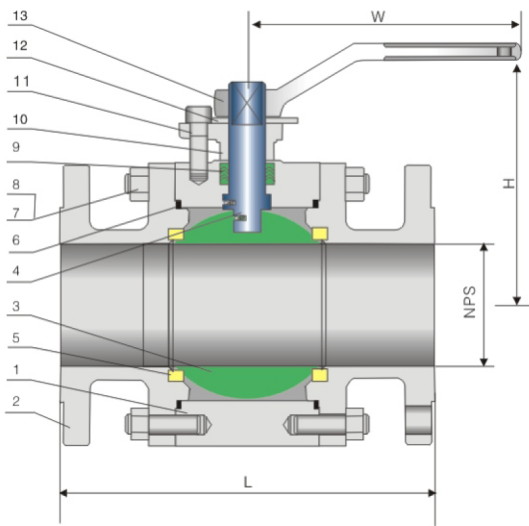

Materials of parts

No	Part Name	Carbon Steel	ASTM Materials 18Cr-9Ni-2Mo	Carbon Steel
1	Body	A105	A182-F316	A350-LF2
2	Bonnet	A105	A182-F316	A350-LF2
3	Ball	A182-F304 ¹⁾	A182-F316	A182-F304 ¹⁾
4	Stem	A276-304	A276-316	A276-304
5	Seat Ring		R.PTFE	
6	Bonnet Gasket	Graphite+304 ²⁾	PTFE	Graphite+304 ²⁾
7	Bonnet Stud	A193-B7	A193-B8	A320-L7
8	Bonnet Stud Nut	A194-2H	A194-8	A194-4
9	Packing		PTFE	
10	Gland Flange	A105	A182-F316	A350-LF2
11	Gland Bolt	A193-B7	A193-B8	A193-B7
12	Stop Plate	Carbon Steel	Carbon Steel+Zn	Carbon Steel
13	Handle		Carbon Steel	

Note: 1)A105+ENP optional
2)Spiral wound construction.



Dimensional datas of ANSI Class 150Lb

NPS DN	1/2 15	3/4 20	1 25	1 1/2 40	2 50	2 1/2 65	3 80	4 100	6 150	8 200	10 250	12 300	in mm
L (RF)	4.25 108	4.62 117	5.00 127	6.50 165	7.00 178	7.50 190	8.00 203	9.00 229	15.50 394	18.00 457	21.00 533	24.00 610	in mm
L1 (BW)	5.50 140	6.00 152	6.50 165	7.50 190	8.50 216	9.50 241	11.12 283	12.00 305	18.00 457	20.50 521	22.00 559	25.00 635	in mm
H	2.12 55	2.12 55	2.50 65	3.38 85	4.00 100	6.00 150	7.00 180	9.25 235	9.88 250	11.00 280	12.62 320	15.38 390	in mm
W	8 200	8 200	12 300	12 300	166 400	16 400	24 600	24 600	24 600	24 600	32 800	32 800	in mm
wt(kg)	3.1 2.6	4.1 3.9	6 5.2	9.5 8.7	12.8 11.8	20 19	26 28	45 47	126 131	216 226	270 295	378 393	RF BW

Applicable Standards:

- STEEL BALL VALVES API 608/API 6D
- STEEL BALL VALVES ISO 14313
- FIRE SAFE, API 607
- ANTI STATICS, API 608
- STEEL VALVES, ASME B16.34
- FACE TO FACE ASME B16.10
- END FLANGES, ASME B16.5
- BUTTWELDING ENDS ASME B16.25
- INSPECTION AND TEST, API 598/ API 6D

Design descriptions:

- FULL PORT DESIGN
- BB.BOLTED BONNET.SPLIT BODY
- FLOATING BALL TYPE
- BLOW-OUT PROOF STEM
- FIRE SAFE CONSTRUCTION
- ANTI STATICS DEVICE
- STOPPER DEVICE
- ISO 5211 MOUNTING PAD
- FLANGED OR BUTTWELDING ENDS
- AVAILABLE WITH WG OPERATOR

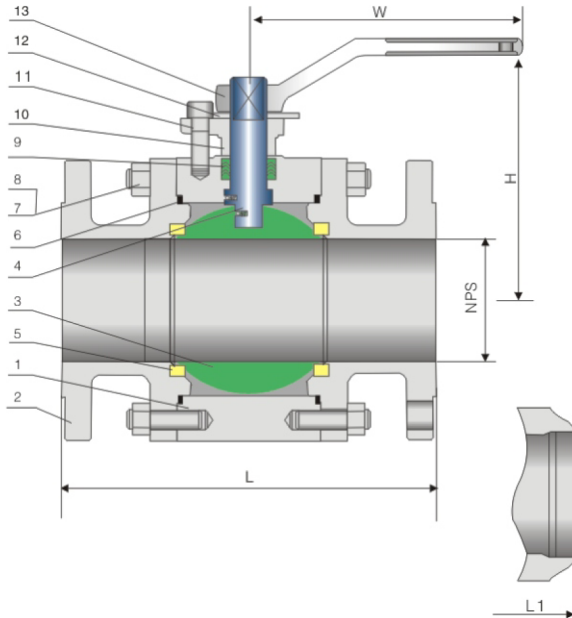

Materials of parts

No	Part Name	Carbon Steel	ASTM Materials 18Cr-9Ni-2Mo	Carbon Steel
1	Body	A105	A182-F316	A350-LF2
2	Bonnet	A105	A182-F316	A350-LF2
3	Ball	A182-F304 ¹⁾	A182-F316	A182-F304 ¹⁾
4	Stem	A276-304	A276-316	A276-304
5	Seat Ring	R.PTFE		
6	Bonnet Gasket	Graphite+304 ²⁾	PTFE	Graphite+304 ²⁾
7	Bonnet Stud	A193-B7	A193-B8	A320-L7
8	Bonnet Stud Nut	A194-2H	A194-8	A194-4
9	Packing	PTFE		
10	Gland Flange	A105	A182-F316	A350-LF2
11	Gland Bolt	A193-B7	A193-B8	A193-B7
12	Stop Plate	Carbon Steel	Carbon Steel+Zn	Carbon Steel
13	Handle	Carbon Steel		

Note: 1)A105+ENP optional
2)Spiral wound construction.

Dimensional datas of ANSI Class 300Lb

NPS DN	1/2 15	3/4 20	1 25	1 1/2 40	2 50	2 1/2 65	3 80	4 100	6 150	8 200	10 250	12 300	in mm
L (RF)	5.50 140	6.00 152	6.50 165	7.50 190	8.50 216	9.50 241	11.12 283	12.00 305	15.88 403	19.75 502	22.38 568	25.50 648	in mm
L1 (BW)	5.50 140	6.00 152	6.50 165	7.50 190	8.50 216	9.50 241	11.12 283	12.00 305	18.00 457	20.50 521	22.00 559	25.00 635	in mm
H	2.12 55	2.12 55	2.50 65	3.38 85	16.00 400	16.00 400	24.00 600	24.00 600	9.88 250	11.00 280	12.62 320	15.38 390	in mm
W	8 200	8 200	12 300	12 300	10 250	12 300	14 350	19 480	24 600	24 600	32 800	32 800	in mm
wt(kg)	3.5 2.8	4.6 3.1	6.7 4.4	10.5 5.5	14.5 8.7	22 13.5	29 17	50 31	141 108	242 194	302 234	423 325	RF BW

Dimensional datas of ANSI Class 600Lb

NPS DN	1/2 15	3/4 20	1 25	1 1/2 40	2 50	2 1/2 65	3 80	4 100	6 150	8 200	10 250	12 300	in mm
L/L1 (RF/BW)	6.50 165	7.50 190	8.50 216	9.50 241	11.50 292	13.00 330	14.00 356	17.00 432	22.00 559	-	-	-	in mm
L2 (RTJ)	-	-	-	-	11.62 295	13.12 333	14.12 359	17.12 435	22.12 562	-	-	-	in mm
H	2.25 58	2.25 58	2.62 68	3.50 89	4.12 105	6.25 158	7.50 190	9.75 247	10.38 262	-	-	-	in mm
W	8 200	12 300	12 300	16 400	16 400	24 600	24 600	24 600	32 800	-	-	-	in mm
wt(kg)	4.5 3.8	5.5 4.1	8 5.6	12.5 7	18 12	27 18	35 23	61 43	172 139	-	-	-	RF BW

Design

The steel ball valves are designed manufactured to provide maximum service life and dependability. All ball valves are full ported and meet the design requirements of American Petroleum Institute standard API 608&API 6D, British standard BS 5351 and generally conform to American Society of Mechanical Engineers standard ASME B16.34 valves are available in a complete range of body/bonnet materials and trims.

Available Modifications

Trim changes
End connection modifications
Packing and gasket changes
Operator mounting
Handwheel extensions

Ranges of Materials

Standard body/bonnet materials include nine grades of carbon, low alloy and stainless steels, for special applications they can be supplied in other grades of alloy and stainless steel, there's a full range of trim materials to match any service optional packing and gasket materials are available for a full range of service conditions.

Pressure equalizing
AS OR FS
Customer specified coatings
Weld end bore changes
Oxygen&chlorine cleaning&packaging

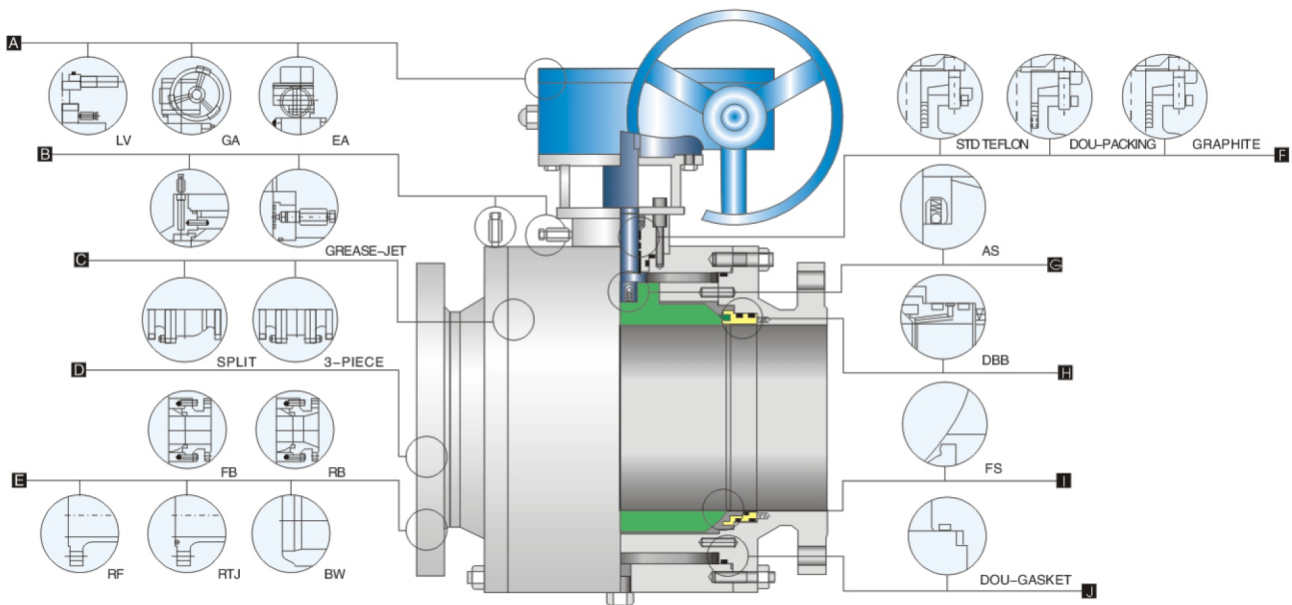

A Operation

Extended lever for easy operation. Also available with gearing, motor actuators, pneumatic or hydraulic actuators for more difficult services

B Grease-jet joint

Installed in prescriptive part accord to the apply and satisfied with ecumenical situations and realize seal in spot with maintenance easily.

C Body & Bonnet

Split or 3-piece, split body & bonnet for 8" & small. Disassembles easily for repair or replacement of internal components.

D BORE

Full bore or reduced bore. Full-bore design provides exceptional flow control.

E End Connectios

A choice of flanged RTJ flanged or buttwelding end for piping flexibility.

F Packing

Std packing multiple v-teflon packing, combined with live loading, maintains packing compression under high-cycle and severe service applications. Graphite packing is used for high-temperature situation.

G AS

Anti statics. A metallic contact is always granted between ball and stem/body to discharge eventual statics build-up during service.

H DBB

Double block & bleed. The body cavity is isolated when the ball is in either fully closed or fully opened position, the medium entrapped in it can easily be bled to avoid over pressure.

I FS

Fire Safe. Designed to API 607 or BS 6755 to grant their operation suitability in case of fire. Secondary metal-to metal seal acts as backup if primary seal is destroyed by fire. Valves ordered for compliance with API 607 will be provided with graphite packing and gaskets.

J Gasket

Adopt high-performance rubber seal ring and spiral wound graphite.

Applicable Standards:

- STEEL BALL VALVES API 608/API 6D
- STEEL BALL VALVES ISO 14313
- FIRE SAFE, API 607
- ANTI STATICS, API 608
- STEEL VALVES, ASME B16.34
- FACE TO FACE ASME B16.10
- END FLANGES, ASME B16.5
- BUTTWELDING ENDS ASME B16.25
- INSPECTION AND TEST, API 598/ API 6D

Design descriptions:

- FULL PORT DESIGN
- BB, BOLTED BONNET, SPLIT BODY
- THREE PIECES BODY FOR 12" & ABOVE
- TRUNNION MOUNTED BALL TYPE
- BLOW-OUT PROOF STEM
- FIRE SAFE CONSTRUCTION
- ANTI STATICS DEVICE
- STOPPER DEVICE
- ISO 5211 MOUNTING PAD
- FLANGED OR BUTTWELDING ENDS
- AVAILABLE WITH WG OPERATOR

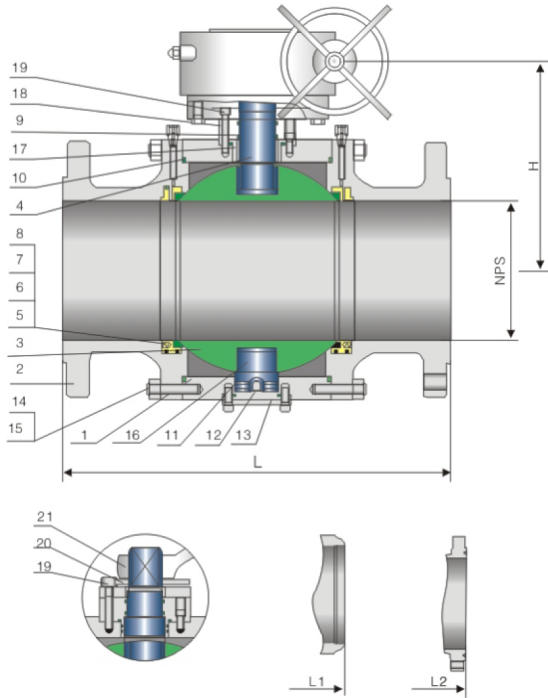

Materials of parts

No	Part Name	Carbon Steel	ASTM Materials 18Cr-9Ni-2Mo	Carbon Steel
1	Body	A105	A182-F316	A350-LF2
2	Bonnet	A105	A182-F316	A350-LF2
3	Ball	A182-F304 ¹⁾	A182-F316	A182-F304 ¹⁾
4	Stem	A276-304	A276-316	A276-304
5	Seat	A105+ENP	A182-F316	A350-LF2+ENP
6	Seat Insert	Glass Filled PTFE		
7	Seat Spring	A313-304	Inconel X-750	A313-304
8	Seat O-Ring	NBR	Viton	Viton
9	Stem O-Ring	NBR	Viton	Viton
10	Bonnet Gasket	Graphite+304 ²⁾	Graphite+316 ²⁾	Graphite+304 ²⁾
11	Bonnet O-ring	NBR	Viton	Viton
12	Antistatic Spring	A313-304	A313-316	A313-304
13	Lower Cover	A182-F304	A182-F316	A182-F304
14	Bonnet Stud	A193-B7	A193-B8	A320-L7
15	Bonnet Stud Nut	A194-2H	A194-8	A194-4
16	Trunnion	A276-304	A276-316	A276-304
17	Trunnion Bearing	304+PTFE	316+PTFE	304+PTFE
18	Gland	A105	A182-F316	A350-LF2
19	Gland Bolt	A193-B7	A193-B8	A193-B7
20	Stop Plate	Carbon Steel	Carbon Steel+Zn	Carbon Steel
21	Handle	Carbon Steel		

Note: 1) A105+ENP optional
2) Spiral wound construction.

Dimensional datas of ANSI Class 150Lb

NPS DN	2 50	2 1/2 65	3 80	4 100	6 150	8 200	10 250	12 300	14 350	16 400	18 450	20 500	24 600	26 650	28 700	30 750	32 800	36 900	in mm
L (RF)	7.00	7.50	8.00	9.00	15.50	18.00	21.00	24.00	27.00	30.00	34.00	36.00	42.00	45.00	49.00	51.00	54.00	60.00	in
	178	190	203	229	394	457	533	610	686	762	864	914	1067	1143	1245	1295	1372	1524	mm
L1 (BW)	8.50	9.50	11.12	12.00	18.00	20.50	22.00	25.00	30.00	33.00	36.00	39.00	45.00	49.00	53.00	55.00	60.00	68.00	in
	216	241	283	305	457	521	559	635	762	838	914	991	1143	1245	1346	1397	1524	1727	mm
H	4.00	6.00	7.00	9.25	9.88	11.00	12.62	15.38	16.50	21.88	23.62	25.00	28.00	29.50	31.50	34.00	36.00	38.50	in
	120	150	180	235	250	280	320	390	420	555	600	635	710	750	800	865	915	980	mm
W	16	16	24	24	24	24	32	32	32	32	32	32	32	40	40	40	40	40	in
	400	400	600	600	600	600	800	800	800	800	800	800	800	1000	1000	1000	1000	1000	mm
wt(kg)	28	35	55	80	190	290	445	570	780	1520	2300	2500	3950	4890	6300	7100	8950	13500	RF
	25	28	49	71	182	277	553	553	747	1481	2266	2460	3904	4939	6362	8149	9000	13570	BW

Dimensional datas of ANSI Class 300Lb

NPS DN	2 50	2 1/2 65	3 80	4 100	6 150	8 200	10 250	12 300	14 350	16 400	18 450	20 500	24 600	26 650	28 700	30 750	32 800	36 900	in mm
L (RF)	8.50	9.50	11.12	12.00	15.88	19.75	22.38	25.50	30.00	33.00	36.00	39.00	45.00	49.00	53.00	55.00	60.00	-	in
	216	241	283	305	403	502	568	648	762	838	914	991	1143	1245	1346	1397	1524	-	mm
L1 (BW)	8.50	9.50	11.12	12.00	18.00	20.50	22.00	25.00	30.00	33.00	36.00	39.00	45.00	49.00	53.00	55.00	60.00	-	in
	216	241	283	305	403	521	559	635	762	838	914	991	1143	1245	1346	1397	1524	-	mm
H	4.00	6.00	7.00	9.25	9.88	11.00	12.62	15.38	16.50	21.88	23.62	25.00	28.00	29.50	31.50	34.00	36.00	-	in
	120	150	180	235	250	280	320	390	420	555	600	635	710	750	800	865	915	-	mm
W	16	16	24	24	24	24	32	32	32	32	32	32	32	40	40	40	40	-	in
	400	400	600	600	600	600	800	800	800	800	800	800	800	1000	1000	1000	1000	-	mm
wt(kg)	30	40	60	90	200	325	490	690	900	1810	2620	2860	4430	5430	6810	7655	9590	-	RF
	24	31	49	72	169	280	424	598	872	1665	2440	2635	4075	4880	6225	7115	9230	-	BW

Applicable Standards:

- STEEL BALL VALVES API 608/API 6D
- STEEL BALL VALVES ISO 14313
- FIRE SAFE, API 607
- ANTI STATICS, API 608
- STEEL VALVES, ASME B16.34
- FACE TO FACE ASME B16.10
- END FLANGES, ASME B16.5
- BUTTWELDING ENDS ASME B16.25
- INSPECTION AND TEST, API 598/ API 6D

Design descriptions:

- FULL PORT DESIGN
- BB, BOLTED BONNET, SPLIT BODY
- THREE PIECES BODY FOR 12" & ABOVE
- TRUNNION MOUNTED BALL TYPE
- BLOW-OUT PROOF STEM
- FIRE SAFE CONSTRUCTION
- ANTI STATICS DEVICE
- STOPPER DEVICE
- ISO 5211 MOUNTING PAD
- FLANGED OR BUTTWELDING ENDS
- AVAILABLE WITH WG OPERATOR

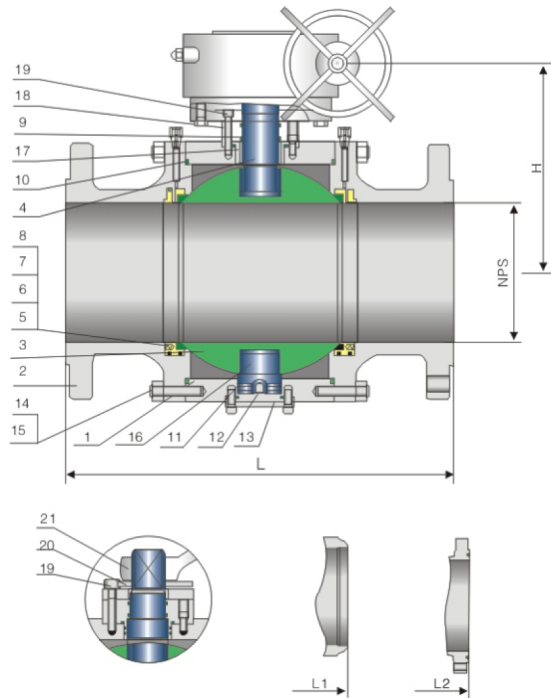

Materials of parts

No	Part Name	Carbon Steel	ASTM Materials 18Cr-9Ni-2Mo	Carbon Steel
1	Body	A105	A182-F316	A350-LF2
2	Bonnet	A105	A182-F316	A350-LF2
3	Ball	A182-F304 ¹⁾	A182-F316	A182-F304 ¹⁾
4	Stem	A276-304	A276-316	A276-304
5	Seat	A105+ENP	A182-F316	A350-LF2+ENP
6	Seat Insert	Glass Filled PTFE		
7	Seat Spring	A313-304	Inconel X-750	A313-304
8	Seat O-Ring	NBR	Viton	Viton
9	Stem O-Ring	NBR	Viton	Viton
10	Bonnet Gasket	Graphite+304 ²⁾	Graphite+316 ²⁾	Graphite+304 ²⁾
11	Bonnet O-ring	NBR	Viton	Viton
12	Antistatic Spring	A313-304	A313-316	A313-304
13	Lower Cover	A182-F304	A182-F316	A182-F304
14	Bonnet Stud	A193-B7	A193-B8	A320-L7
15	Bonnet Stud Nut	A194-2H	A194-8	A194-4
16	Trunnion	A276-304	A276-316	A276-304
17	Trunnion Bearing	304+PTFE	316+PTFE	304+PTFE
18	Gland	A105	A182-F316	A350-LF2
19	Gland Bolt	A193-B7	A193-B8	A193-B7
20	Stop Plate	Carbon Steel	Carbon Steel+Zn	Carbon Steel
21	Handle	Carbon Steel		

Note: 1) A105+ENP optional
2) Spiral wound construction.

Dimensional datas of ANSI Class 600Lb

NPS DN	2 50	2 1/2 65	3 80	4 100	6 150	8 200	10 250	12 300	14 350	16 400	18 450	20 500	24 600	26 650	28 700	in mm
L/L1 (RF/BW)	11.50	13.00	14.00	17.00	22.00	26.00	31.00	33.00	35.00	39.00	43.00	47.00	55.00	57.00	61.00	in
	292	330	356	432	559	660	787	838	889	991	1092	1194	1397	1448	1549	mm
L2 (RTJ)	11.62	13.12	14.12	17.12	22.12	26.12	31.12	33.12	35.12	39.12	43.12	47.25	55.38	57.50	61.50	in
	295	333	359	435	562	664	791	841	892	994	1095	1200	1407	1461	1562	mm
H	6.50	7.00	7.88	11.00	12.25	14.00	16.12	18.00	19.25	21.00	24.88	25.62	30.12	31.88	34.62	in
	165	180	200	280	310	355	410	455	490	535	630	650	765	810	880	mm
W	16	24	24	24	32	32	32	32	32	32	40	40	40	40	40	in
	400	600	600	600	800	800	800	800	800	800	1000	1000	1000	1000	1000	mm
wt(kg)	34	53	65	125	245	505	640	910	1380	2250	3400	3850	4900	6700	8300	RF
	27	43	49	95	188	418	495	740	1185	1960	3050	3406	4275	6025	7590	BW

Dimensional datas of ANSI Class 900Lb

NPS DN	2 50	2 1/2 65	3 80	4 100	6 150	8 200	10 250	12 300	14 350	16 400	18 450	20 500	24 600	in mm
L/L1 (RF/BW)	14.50	16.50	15.00	18.00	24.00	29.00	33.00	38.00	40.50	44.50	48.00	52.00	61.00	in
	368	419	381	457	610	737	965	965	1029	1130	1219	1321	1549	mm
L2 (RTJ)	14.62	16.62	15.12	18.12	24.12	29.12	38.12	38.12	40.88	44.88	48.50	52.50	61.75	in
	371	422	384	460	613	740	968	968	1038	1140	1232	1334	1568	mm
H	6.72	7.50	8.25	11.38	12.62	15.38	18.50	18.50	20.88	24.00	26.00	27.50	30.75	in
	170	190	210	290	320	390	470	470	530	610	660	700	780	mm
W	24	24	24	32	32	32	32	32	32	40	40	40	40	in
	600	600	600	800	800	800	800	500	800	1000	1000	1000	1000	mm
wt(kg)	45	65	73	135	360	650	1350	1350	1890	3100	4300	4950	7100	RF/RTJ
	37	53	56	98	291	545	1145	1145	1650	2750	3875	4410	6485	BW

Applicable Standards:

- STEEL BALL VALVES API 608/API 6D
- STEEL BALL VALVES ISO 14313
- FIRE SAFE, API 607
- ANTI STATICS, API 608
- STEEL VALVES, ASME B16.34
- FACE TO FACE ASME B16.10
- END FLANGES, ASME B16.5
- BUTTWELDING ENDS ASME B16.25
- INSPECTION AND TEST, API 598/ API 6D

Design descriptions:

- FULL PORT DESIGN
- BB, BOLTED BONNET, SPLIT BODY
- THREE PIECES BODY FOR 12" & ABOVE
- TRUNNION MOUNTED BALL TYPE
- BLOW-OUT PROOF STEM
- FIRE SAFE CONSTRUCTION
- ANTI STATICS DEVICE
- STOPPER DEVICE
- ISO 5211 MOUNTING PAD
- FLANGED OR BUTTWELDING ENDS
- AVAILABLE WITH WG OPERATOR

Materials of parts

No	Part Name	Carbon Steel	ASTM Materials 18Cr-9Ni-2Mo	Carbon Steel
1	Body	A105	A182-F316	A350-LF2
2	Bonnet	A105	A182-F316	A350-LF2
3	Ball	A182-F304 ¹⁾	A182-F316	A182-F304 ¹⁾
4	Stem	A276-304	A276-316	A276-304
5	Seat	A105+ENP	A182-F316	A350-LF2+ENP
6	Seat Insert	Glass Filled PTFE		
7	Seat Spring	A313-304	Inconel X-750	A313-304
8	Seat O-Ring	NBR	Viton	Viton
9	Stem O-Ring	NBR	Viton	Viton
10	Bonnet Gasket	Graphite+304 ²⁾	Graphite+316 ²⁾	Graphite+304 ²⁾
11	Bonnet O-ring	NBR	Viton	Viton
12	Antistatic Spring	A313-304	A313-316	A313-304
13	Lower Cover	A182-F304	A182-F316	A182-F304
14	Bonnet Stud	A193-B7	A193-B8	A320-L7
15	Bonnet Stud Nut	A194-2H	A194-8	A194-4
16	Trunnion	A276-304	A276-316	A276-304
17	Trunnion Bearing	304+PTFE	316+PTFE	304+PTFE
18	Gland	A105	A182-F316	A350-LF2
19	Gland Bolt	A193-B7	A193-B8	A193-B7
20	Stop Plate	Carbon Steel	Carbon Steel+Zn	Carbon Steel
21	Handle	Carbon Steel		

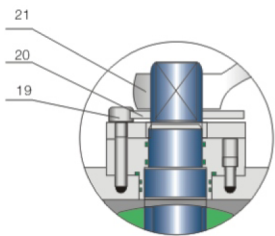
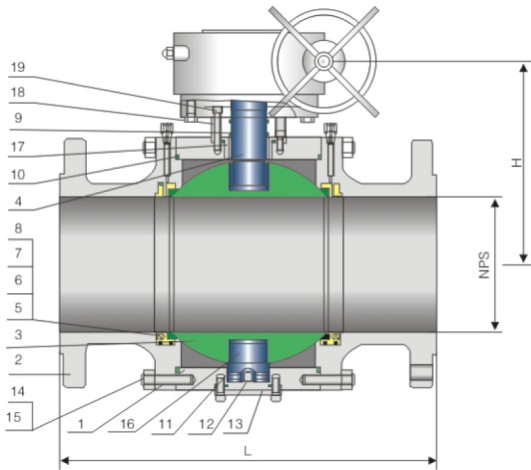

Note: 1) A105+ENP optional
2) Spiral wound construction.

Dimensional datas

NPS	DN	L/L1 (RF/BW)		L2 (RTJ)		H		W		WT(kg)		L/L1 (RF/BW)		L2 (RTJ)		H		W		WT(kg)	
ANSI Class1500Lb																					
2	50	14.50	368	14.62	371	6.75	170	24	600	55	40	17.75	451	17.88	454	7.50	190	24	600	68	57
2 1/2	65	16.50	419	16.62	422	7.50	190	24	600	75	55	20.00	508	21.25	540	9.00	230	32	800	95	74
3	80	18.50	470	18.62	473	5.25	210	32	800	95	65	22.75	578	23.00	584	11.00	280	32	800	120	91
4	100	21.50	546	21.62	549	11.38	290	32	800	150	115	26.50	673	26.88	683	14.12	360	32	800	185	122
6	150	27.75	705	28.00	711	13.00	330	32	800	540	420	36.00	914	36.50	927	15.75	400	32	800	675	555
8	200	32.75	832	33.12	841	15.75	400	32	800	880	685	40.25	1022	40.88	1038	18.88	480	40	1000	1100	918
10	250	39.00	991	39.38	1000	17.38	440	32	800	1360	1025	50.00	1270	50.88	1292	20.50	520	40	1000	1650	1355
12	300	44.50	1130	45.12	1146	22.00	560	40	1000	1980	1555	56.00	1422	56.88	1445	26.38	670	40	1000	2300	1950
14	350	49.50	1257	50.25	1276	25.25	640	40	1000	3100	2600	-	-	-	-	-	-	-	-	-	-
16	400	54.50	1384	55.38	1407	27.12	690	40	1000	4650	3930	-	-	-	-	-	-	-	-	-	-
in	mm	in	mm	in	mm	in	mm	in	mm	RF/RTJ	bw	in	mm	in	mm	in	mm	in	mm	RF/RTJ	BW

Applicable Standards:

DESIGN & MANUFACTURE CONFORM WITH: API 6D/ISO 14313、ASME B16.34

CONNECTION DIMENSION CONFORMS WITH: ASME B16.5、DN EN 1092

FIRE RESISTANCE DESIGN CONFORMS WITH: API 607/ISO 10497

INSPECTION & TEST CONFORMS WITH: API 6D、ISO 5208、API 598

MATERIAL CONFORMS WITH: ISO 15156

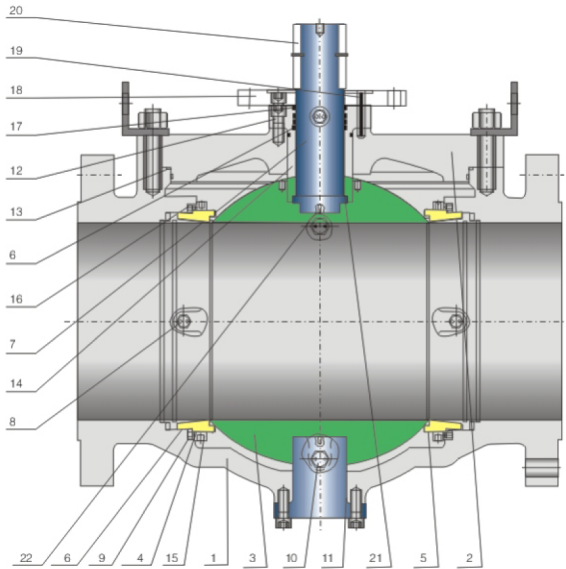

No	Part Name	No	Part Name
1	Body	12	Screw
2	Lid	13	Body gasket
3	Ball	14	Support cover
4	Seat	15	Seat retainer ring
5	Sealing ring	16	Spring support cover
6	O-ring	17	Packing
7	Stem	18	Connected disk
8	Seat grease injection valve	19	Elastic cylindrical pin
9	Spring	20	Flat key
10	Blow-down valve	21	Stem gasket
11	Ball lubricating bearing	22	Antistatic spring

Features and Application:

This product is a new type top entry combination ball valve, the seat can be installed and move around the body. Through the thread, the outer margin of the seat connected to the retainer ring. There is spring on the support cover, which installed on the valve body, and the retainer ring can compress spring. The fabrication holes are on the outer margin of the seat and the retainer ring. This new type product adopts total body design, the compensation can be automatically, the possibility of leakage is small, safety in use, vibrate resistance, and double seal. The ball is installed from the top part, so can finish the maintenance without removing the pipe, it is very convenient.

Materials of parts

Body	WCB/LCB/CF8M/CF8/CF3M/CF3/WC6/WC9/CD3MN
Lid	WCB/LCB/CF8M/CF8/CF3M/CF3/WC6/WC9/CD3MN
Ball	A105+ENP/LF2+ENP/F304/F316/F304L/F316L/F51
Seat	A105+ENP/LF2+ENP/F304/F316/F304L/F316L/F51
Stem	A105+ENP/LF2+ENP/F304/F316/F304L/F316L/F51
Seat ring	PTFE/MYLON/PEEK/TEFLON
O-ring	VITON/NBR
Bolt	B7M/B8M/L7M/B16M
Support cover	A105+ENP/LF2+ENP/F304/F316/F304L/F316L/F51
Spring	17-4PH/17-7PH/Inconel
Bearing	304+PTFE/316+PTFE
Gasket	Flexible graphite+PTFE

Materials could be choosed according to customers' requirement & working condition.

Applicable Standards:

DESIGN & MANUFACTURE CONFORM WITH: API 6D/ISO 14313、ASME B16.34

CONNECTION DIMENSION CONFORMS WITH: ASME B16.5、DN EN 1092

FIRE RESISTANCE DESIGN CONFORMS WITH: API 607/ISO 10497

INSPECTION & TEST CONFORMS WITH: API 6D、ISO 5208、API 598

MATERIAL CONFORMS WITH: ISO 15156

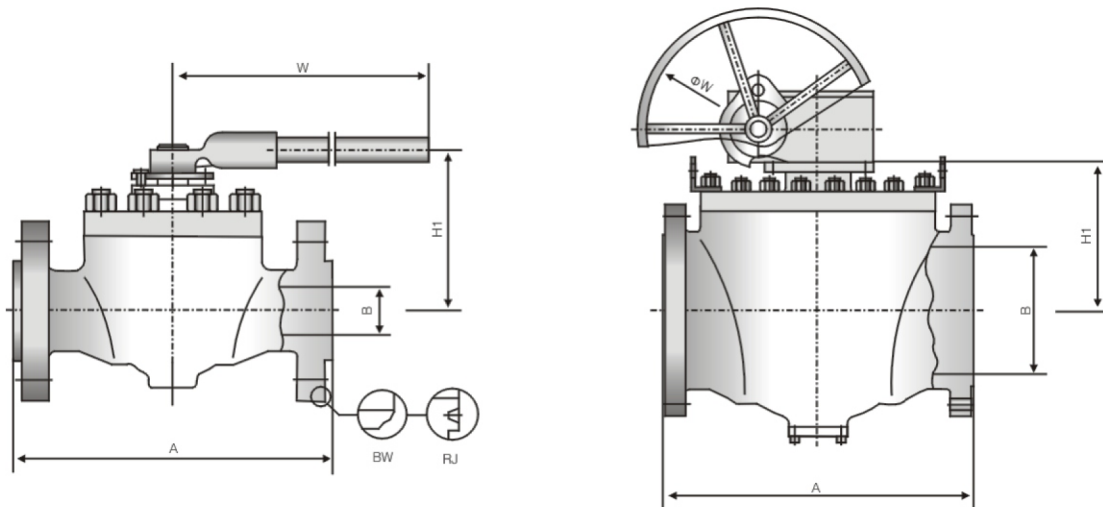

Dimensional datas

NPS inch	DN	A mm	B mm	H1 mm	W mm	WT kg	T N.m	NPS inch	DN	A mm	B mm	H1 mm	W mm	WT kg	T N.m
ANSI Class 150Lb															
2	50	292	51	207	300	30	50	★14	350	889	334	455	600	760	2426
3	80	356	76	223	400	57	65	★16	400	991	385	460	600	1100	3016
4	100	432	100	280	450	100	151	★18	450	1092	436	503	600	1512	4574
★6	150	559	150	275	460	215	320	★20	500	1194	487	560	700	1930	6016
★8	200	660	201	321	460	407	1020	★24	600	1397	589	610	700	3200	9750
★10	250	787	252	355	600	560	1085	★28	700	1549	684	730	700	4600	14540
★12	300	838	303	470	600	710	1562	★30	750	1651	735	800	760	5630	18005

Dimensional datas

NPS inch	DN	A mm	B mm	H1 mm	W mm	WT kg	T N.m	NPS inch	DN	A mm	B mm	H1 mm	W mm	WT kg	T N.m
ANSI Class 300Lb															
2	50	292	51	211	300	36	86	★14	350	889	334	460	600	766	3800
3	80	356	76	226	500	63	110	★16	400	991	385	480	600	1106	5376
4	100	432	100	286	550	106	270	★18	450	1092	436	508	600	1519	8000
★6	150	559	150	282	460	221	500	★20	500	1194	487	565	600	2010	10610
★8	200	660	201	325	460	412	1620	★24	600	1397	589	617	760	3208	17280
★10	250	787	252	360	600	566	1824	★28	700	1549	684	678	760	4607	25102
★12	300	838	303	420	600	715	2632	★30	750	1651	735	738	760	5638	31664

Note: ★ Turbine drives

Top Entry Combination Ball Valve 600Lb\900Lb/1500Lb



Applicable Standards:

DESIGN & MANUFACTURE CONFORM WITH: API 6D/ISO 14313、ASME B16.34
 CONNECTION DIMENSION CONFORMS WITH: ASME B16.5、DN EN 1092
 FIRE RESISTANCE DESIGN CONFORMS WITH: API 607/ISO 10497
 INSPECTION & TEST CONFORMS WITH: API 6D、ISO 5208、API 598
 MATERIAL CONFORMS WITH: ISO 15156

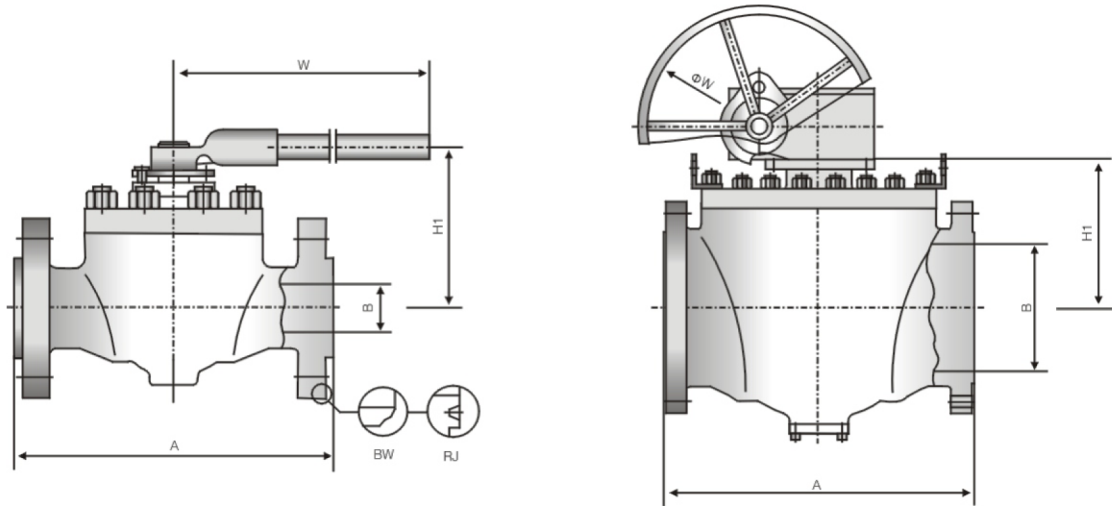

Dimensional datas

NPS inch	DN	A mm	B mm	H1 mm	W mm	WT kg	T N.m	NPS inch	DN	A mm	B mm	H1 mm	W mm	WT kg	T N.m
ANSI Class 600Lb															
2	50	292	51	215	500	41	148	★ 14	350	889	334	465	700	770	7255
3	80	356	76	232	600	67	200	★ 16	400	991	385	470	700	1112	9174
4	100	432	100	294	600	110	460	★ 18	450	1092	436	512	760	1523	13520
★ 6	150	559	150	287	600	226	908	★ 20	500	1194	487	570	760	1940	18034
★ 8	200	660	201	324	600	417	2560	★ 24	600	1397	589	622	760	3213	29512
★ 10	250	787	252	365	600	570	3048	★ 28	700	1549	684	742	760	4612	42264
★ 12	300	838	303	480	700	720	4300	★ 30	750	1651	735	817	850	5640	58864

Dimensional datas

NPS inch	DN	A mm	B mm	H1 mm	W mm	WT kg	T N.m	NPS inch	DN	A mm	B mm	H1 mm	W mm	WT kg	T N.m
ANSI Class 900Lb															
2	50	368	49	212	650	52	208	★ 12	300	965	303	507	700	1300	6000
3	80	381	74	227	700	110	280	★ 14	350	1029	322	520	700	1695	10220
4	100	457	100	277	800	200	650	★ 16	400	1130	373	538	760	2560	12968
★ 6	150	610	150	283	600	430	1298	★ 18	450	1219	423	580	760	3400	19054
★ 8	200	737	201	334	600	800	3596	★ 20	500	1321	471	625	760	4400	25452
★ 10	250	838	252	380	600	1000	4306	★ 24	600	1549	589	690	850	7200	38655

Dimensional datas

NPS inch	DN	A mm	B mm	H1 mm	W mm	WT kg	T N.m	NPS inch	DN	A mm	B mm	H1 mm	W mm	WT kg	T N.m
ANSI Class 1500Lb															
2	50	368	49	212	600	56	330	★ 10	250	991	239	398	700	1438	6720
3	80	470	74	236	930	153	440	★ 12	300	1130	287	520	700	2017	14520
4	100	546	100	295	460	278	1034	★ 14	350	1257	315	560	760	2612	32600
★ 6	150	705	144	303	600	600	2084	★ 16	400	1384	360	570	760	3890	49650
★ 8	200	832	192	354	600	1100	5496	★ 18	450	1477	405	592	760	5100	66350

Note: ★ Turbine drives

Applicable Standards :

DESIGN & MANUFACTURE CONFORM WITH; API 6D/ ISO 14313、ASME B16.34
 CONNECTION DIMENSION CONFORMS WITH; ASME B16.25、DIN EN 12627
 FIRE RESISTANCE DESIGN CONFORMS WITH; API 607/ISO 10497
 INSPECTION & TEST CONFORMS WITH; API 6D、ISO 5208、API 598
 MATERIAL CONFORMS WITH; ISO 15156

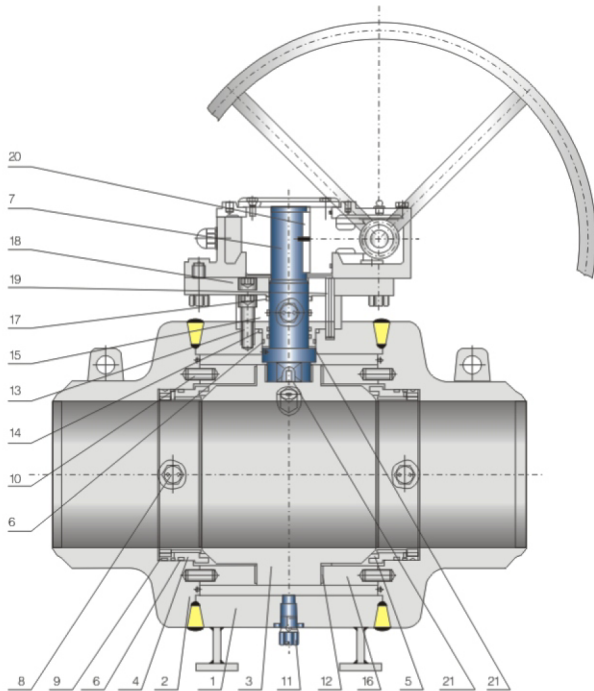

Materials of parts

No	Part Name	No	Part Name
1	Body	12	Ball lubricating bearing
2	Left-right body	13	Screw
3	Ball	14	Bonnet gasket
4	Seat	15	Support cover
5	Sealing ring	16	Die holder
6	O-ring	17	Packing
7	Stem	18	Terminal pad
8	Seat grease injection valve	19	Spring pin
9	Spring	20	Flat key
10	straight pin	21	Stem gasket
11	Blow-down valve	22	Static-free spring

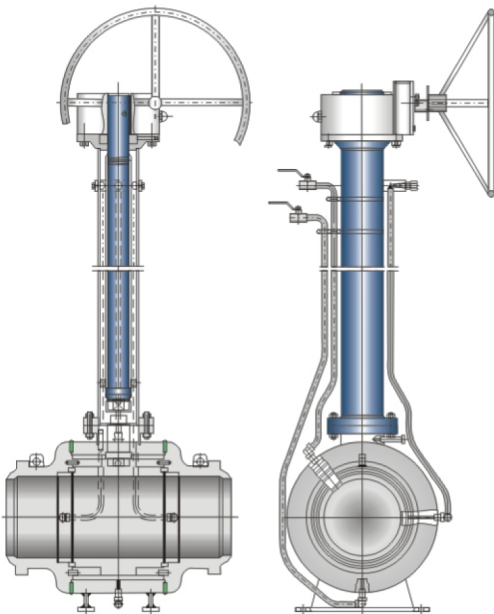

Ground extended product structure diagram

Materials of parts

Body	A105/LF2/F304/F316/F304L/F316L/F11/F22/F51
Ball	A105+ENP/LF2+ENP/F304/F316/F304L/F316L/F51
Seat	A105+ENP/LF2+ENP/F304/F316/F304L/F316L/F51
Stem	A105+ENP/LF2+ENP/F304/F316/F304L/F316L/F51
Sealing ring	PTFE/NYLON/PEEK/TEFLON
O-ring	VITON/NBR
Screw	B7M/B8M/L7M/B16M
Support cover	A105+ENP/LF2+ENP/F304/F316/F304L/F316L/F51
Die holder	A105+ENP/LF2+ENP/F304/F316/F304L/F316L/F51
Spring	17-4PH/17-7PH/Inconel
Bearing	304+PTFE/316+PTFE
Gasket	Flexible graphite+304/PTFE

Materials could be choosed according to customers' requirement & working condition.

Applicable Standards:

DESIGN & MANUFACTURE CONFORM WITH: API 6D/ ISO 14313、ASME B16.34
 CONNECTION DIMENSION CONFORMS WITH: ASME B16.25、DIN EN 12627
 FIRE RESISTANCE DESIGN CONFORMS WITH: API 607/ISO 10497
 INSPECTION & TEST CONFORMS WITH: API 6D、ISO 5208、API 598
 MATERIAL CONFORMS WITH: ISO 15156

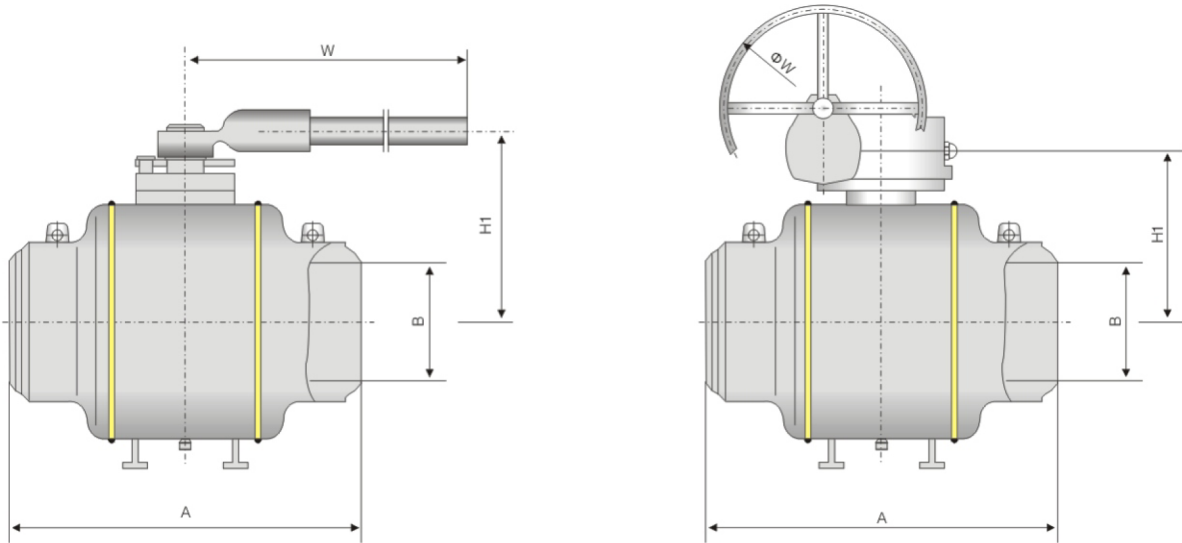

Dimensional datas

NPS inch	DN	A mm	B mm	H1 mm	W mm	WT kg	T N.m	NPS inch	DN	A mm	B mm	H1 mm	W mm	WT kg	T N.m
ANSI Class 150Lb															
2	50	216	51	146	300	12	50	★ 14	350	762	334	410	600	860	2426
3	80	283	76	170	400	28	65	★ 16	400	838	385	460	600	980	3016
4	100	305	100	204	450	42	151	★ 18	450	914	436	520	600	1210	4574
★ 6	150	457	150	260	460	125	320	★ 20	500	991	487	560	700	1760	6016
★ 8	200	521	201	300	460	220	1020	★ 24	600	1143	589	600	700	2010	9750
★ 10	250	559	252	340	600	340	1085	★ 28	700	1346	684	730	700	3200	14540
★ 12	300	635	303	385	600	520	1562	★ 30	750	1397	735	840	760	4120	18005

Dimensional datas

NPS inch	DN	A mm	B mm	H1 mm	W mm	WT kg	T N.m	NPS inch	DN	A mm	B mm	H1 mm	W mm	WT kg	T N.m
ANSI Class 300Lb															
2	50	216	51	170	300	16	86	★ 14	350	762	334	420	600	980	3800
3	80	283	76	185	500	35	110	★ 16	400	838	385	470	600	1210	5376
4	100	305	100	210	550	60	270	★ 18	450	914	436	530	600	1520	8000
★ 6	150	457	150	260	460	150	500	★ 20	500	991	487	590	600	2010	10610
★ 8	200	521	201	310	460	250	1620	★ 24	600	1143	589	600	760	2520	17280
★ 10	250	559	252	345	600	350	1824	★ 28	700	1346	684	750	760	3600	25012
★ 12	300	635	303	390	600	580	2632	★ 30	750	1397	735	850	760	4620	31664

Note: ★ Turbine drives

Applicable Standards :

DESIGN & MANUFACTURE CONFORM WITH; API 6D/ ISO 14313、ASME B16.34
 CONNECTION DIMENSION CONFORMS WITH; ASME B16.25、DIN EN 12627
 FIRE RESISTANCE DESIGN CONFORMS WITH; API 607/ISO 10497
 INSPECTION & TEST CONFORMS WITH; API 6D、ISO 5208、API 598
 MATERIAL CONFORMS WITH; ISO 15156

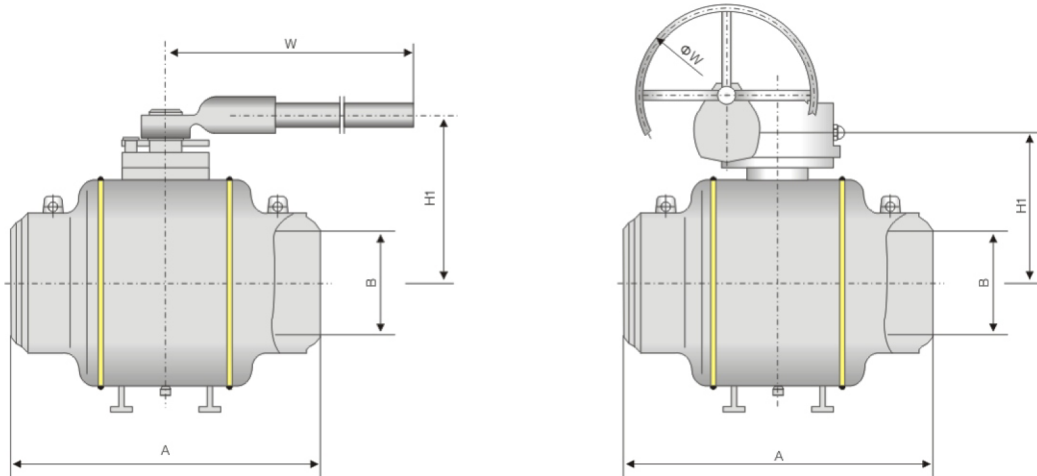

Dimensional datas

NPS inch	DN	A mm	B mm	H1 mm	W mm	WT kg	T N.m	NPS inch	DN	A mm	B mm	H1 mm	W mm	WT kg	T N.m
ANSI Class 600Lb															
2	50	292	51	185	500	27	148	★ 14	350	889	334	450	700	1228	7255
3	80	356	76	190	600	48	200	★ 16	400	991	385	500	700	1705	9174
4	100	432	100	220	600	95	460	★ 18	450	1092	436	560	760	2380	13520
★6	150	559	150	270	600	210	908	★ 20	500	1194	487	620	760	2875	18034
★8	200	660	201	320	600	405	2560	★ 24	600	1397	589	750	760	4830	29512
★10	250	787	252	350	600	655	3048	★ 28	700	1549	684	880	760	5900	42264
★12	300	838	303	400	700	915	4300	★ 30	750	1651	735	960	850	7200	58864

Dimensional datas

NPS inch	DN	A mm	B mm	H1 mm	W mm	WT kg	T N.m	NPS inch	DN	A mm	B mm	H1 mm	W mm	WT kg	T N.m
ANSI Class 900Lb															
2	50	368	49	180	650	40	208	★ 12	300	965	303	450	700	1270	6000
3	80	381	74	208	700	70	280	★ 14	350	1029	322	550	700	1515	10220
4	100	457	100	222	800	110	650	★ 16	400	1130	373	650	760	2420	12968
★6	150	610	150	270	600	255	1298	★ 18	450	1219	423	750	760	2740	19054
★8	200	737	201	325	600	525	3596	★ 20	500	1321	471	830	760	3325	25452
★10	250	838	252	360	600	810	4306	★ 24	600	1549	589	950	850	4800	38655

Dimensional datas

NPS inch	DN	A mm	B mm	H1 mm	W mm	WT kg	T N.m	NPS inch	DN	A mm	B mm	H1 mm	W mm	WT kg	T N.m
ANSI Class 1500Lb															
2	50	368	49	175	600	50	330	★ 8	200	832	192	360	600	580	5496
3	80	470	74	232	930	115	440	★ 10	250	991	239	410	700	1120	6720
4	100	546	100	395	460	170	1034	★ 12	300	1130	287	500	700	1492	14520
★6	150	705	144	300	600	402	2084	★ 14	350	1257	315	560	760	2140	32600

Note: ★ Turbine drives

Applicable Standards:

DESIGN & MANUFACTURE CONFORM WITH: API 608, ASME B16.34
 CONNECTION DIMENSION CONFORMS WITH: ASME B16.5, DIN EN 1092
 FIRE RESISTANCE DESIGN CONFORMS WITH: API 607/ISO 10497
 INSPECTION & TEST CONFORMS WITH: ISO 5208, API 598
 MATERIAL CONFORMS WITH: ISO 15156

No	Part Name	No	Part Name
1	Body	9	Spring
2	Left-right body	10	Seat washer
3	Ball	11	Screw
4	Seat	12	Packing bushing
5	Graphite sealing ring	13	Packing
6	Pressure ring	14	Bushing
7	Stem	15	Nut
8	Lower lid	16	Stud

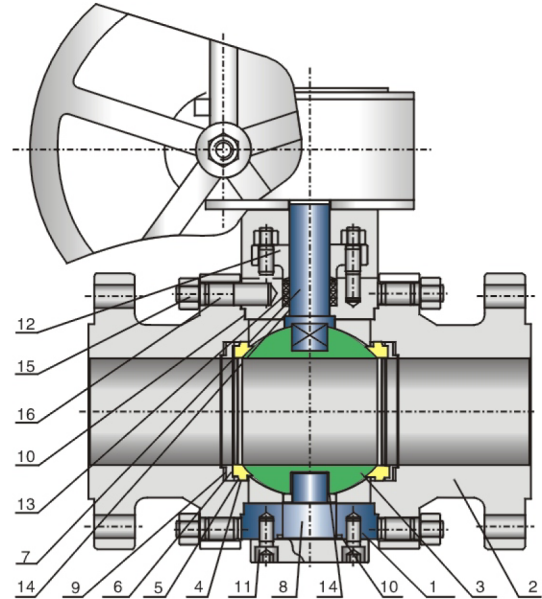

Characteristics & Application

1. The product is suitable for harsh work conditions, can be used for a wide temperature range, such as the high temperature, corrosive media and so on.
2. The tungsten-chromium alloy solid stainless steel seat firm by the spring, this kind of design can be applied to a wide range of operating conditions, it not only improves the seal performance, but also has the excellent features of long service life and maintenance-free.
3. The stable torque is easy to use, and cheaper in cost.
4. High-quality sealing performance depends on a high level of processing technology, through this way the ball can have a close contact with seat.
5. Even in a low temperature, the spring installed in the seat can also ensure the ball have a close contact with the seat, so in a wide temperature range, under high-pressure difference and high frequency, the torque can still be open and closed stably.
6. composed of different materials, the valve can be used for different temperatures, up to 500° c(932° F)
7. After the surface-hardening treatment, the ball valve seat can be more widely used, on as cement, paper pulp, as well as other corrosive occasions, and have a long lifetime. What's more, the fixed ball with a unique design is suitable for the media containing dust.

Materials of parts

Body	WCB/A105/CF8M/F316/CF8/F304/CF3M F316L/CF3/F304L/CD3MN/F51
Bonnet	WCB/A105/CF8M/F316/CF8/F304/CF3M F316L/CF3/F304L/CD3MN/F51
Ball	(F304/F316/F304L/F316L/F51) +Ionitriding/Hard Chromium/Nialloy surfacing
Seat	(F304/F316/F304L/F316L/F51) +Stellite
Stem	F6a/A105+ENP/F304/F316/F304L/F316L/F51
Sealing ring	Flexible graphite
Lower lid	A105+ENP/F316/F304/F316L/F304L/F51
Bolt	B7M/B8M
Nut	B7M/B8M
Packing	Flexible graphite
Spring	17-4PH/Inconel series
Bushing	(304/316) +Ion nitriding
Seal gasket	304+Flexible graphite

Materials could be choosed according to customers' requirement & working condition.

Floating Structure Series

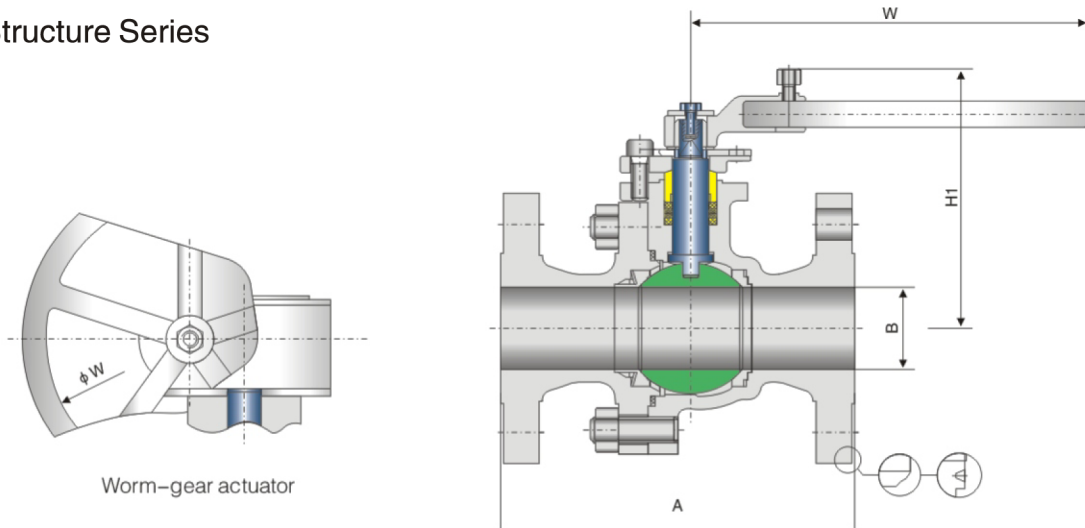

Worm-gear actuator

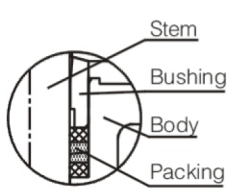

Flexible graphite is of high-temperature and fire resistance function.

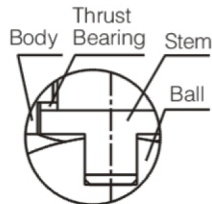

If the packing become loose, the convex side of the stem can play a role in the prevention from stem belch out.

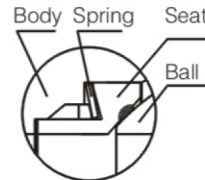

The spring can relieve the pipe stress and heat expansion, to ensure the stability of the operation

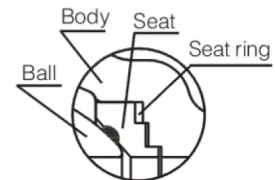

Through the co-operation of the seat ring and the body, ball valve can maintain a stable operation in working temperature range-29°C~500°C

Dimensional datas

NPS inch	DN	A mm	B mm	H1 mm	W mm	WT kg	T N.m	NPS inch	DN	A mm	B mm	H1 mm	W mm	WT kg	T N.m
ANSI Class 150Lb															
1/2	15	108	13	60	200	2.5	5	2 1/2	65	191	65	160	600	18	80
3/4	20	117	19	65	200	3.5	8	3	80	203	76	190	600	25	120
1	25	127	25	75	250	5.8	11	4	100	229	100	210	700	38	150
1 1/2	40	165	32	98	350	7.5	25	★6	150	394	150	360	460	106	600
2	50	178	51	128	350	11	45	★8	200	457	201	523	600	180	1050

Dimensional datas

NPS inch	DN	A mm	B mm	H1 mm	W mm	WT kg	T N.m	NPS inch	DN	A mm	B mm	H1 mm	W mm	WT kg	T N.m
ANSI Class 300Lb															
1/2	15	140	13	60	200	3	11	2 1/2	65	241	65	160	600	30	160
3/4	20	152	19	65	200	5	18	3	80	383	76	190	600	40	221
1	25	165	25	75	250	8	40	4	100	305	100	210	700	65	392
1 1/2	40	191	32	98	350	11	57	★6	150	403	150	360	600	122	1240
2	50	216	51	128	350	18	90	★8	200	502	201	523	600	246	2100

Dimensional datas

NPS inch	DN	A mm	B mm	H1 mm	W mm	WT kg	T N.m	NPS inch	DN	A mm	B mm	H1 mm	W mm	WT kg	T N.m
ANSI Class 600Lb															
2	50	292	51	150	450	28	266	3	80	356	76	210	700	40	644
2 1/2	65	330	65	180	450	45	504	★4	100	432	100	270	600	65	1078

Note: ★ Worm-gear actuator

Fixed Structure Series

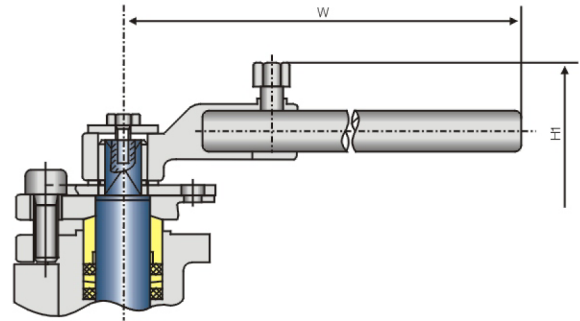
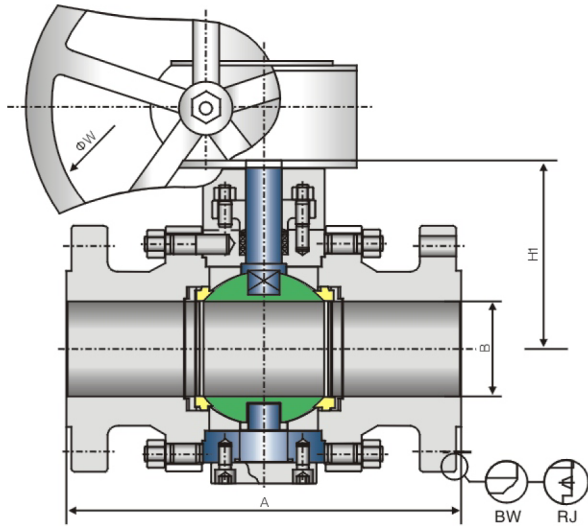

Manual operated

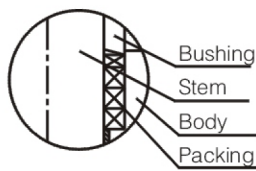

Flexible graphite is of high-temperature and fire resistance function.

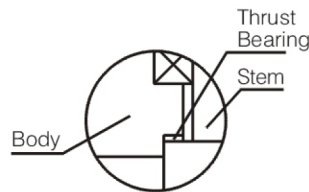

If the packing become loose, the convex side of the stem can play a role in the prevention from stem belch out.



Through the co-operation of the seat ring and the body, ball valve can maintain a stable operation in working temperature range-29°C~500°C

Dimensional datas

NPS inch	DN	A mm	B mm	H1 mm	W mm	WT kg	T N.m	NPS inch	DN	A mm	B mm	H1 mm	W mm	WT kg	T N.m
ANSI Class 150Lb															
2	50	178	51	172	350	16	72	★10	250	533	252	350	600	280	1437
2½	65	191	65	184	400	26	92	★12	300	610	303	380	600	460	2152
3	80	203	76	196	500	35	123	★14	350	686	334	415	600	580	3234
4	100	229	100	225	650	51	240	★16	400	762	385	450	700	790	3797
★6	150	394	150	290	460	103	640	★18	450	864	436	490	700	930	4574
★8	200	457	201	320	600	170	1082	★20	500	914	487	540	700	1288	6875

Dimensional datas

NPS inch	DN	A mm	B mm	H1 mm	W mm	WT kg	T N.m	NPS inch	DN	A mm	B mm	H1 mm	W mm	WT kg	T N.m
ANSI Class 300Lb															
2	50	216	51	172	350	22	119	★10	250	568	252	356	600	310	2170
2½	65	241	65	184	400	34	149	★12	300	648	303	388	600	512	2985
3	80	283	76	196	500	45	255	★14	350	762	334	425	700	612	4030
4	100	305	100	225	650	92	402	★16	400	838	385	466	700	1010	6424
★6	150	403	150	295	600	180	680	★18	450	914	436	502	700	1183	9963
★8	200	502	201	325	600	246	1620	★20	500	991	487	550	760	1353	13213

Note: ★ Worm-gear actuator

Fixed Structure Series

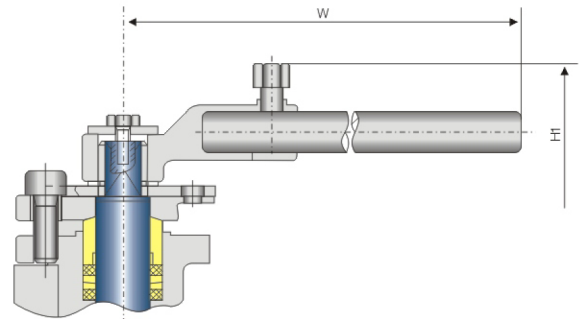
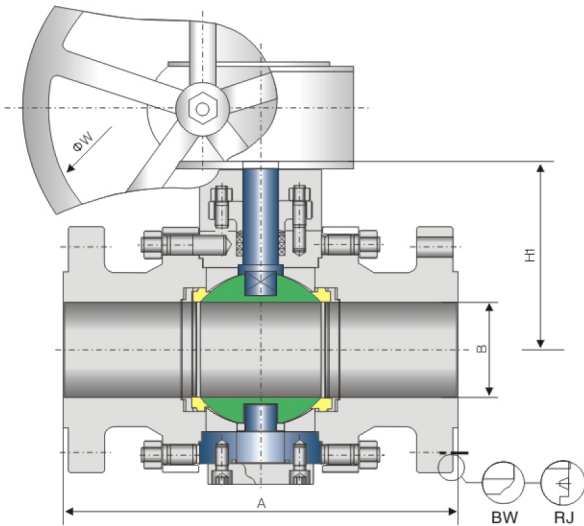

Manual operated

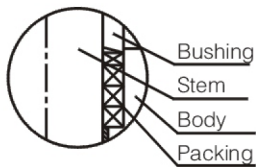

Flexible graphite is of high-temperature and fire resistance function.

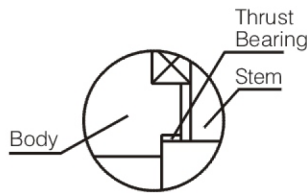

If the packing become loose, the convex side of the stem can play a role in the prevention from stem belch out.



Through the co-operation of the seat ring and the body, ball valve can maintain a stable operation in working temperature range -29°C~500°C

Dimensional datas

NPS inch	DN	A mm	B mm	H1 mm	W mm	WT kg	T N.m	NPS inch	DN	A mm	B mm	H1 mm	W mm	WT kg	T N.m
ANSI Class 600Lb															
2	50	292	51	185	500	30	148	★10	250	787	252	362	700	600	4021
3	80	356	76	205	600	56	200	★12	300	838	303	398	700	830	5567
4	100	432	100	235	600	84	460	★14	350	889	334	435	700	1140	9695
★6	150	559	150	300	600	230	908	★16	400	991	385	478	760	1530	12103
★8	200	660	201	350	600	350	2560	★18	450	1092	436	522	760	2120	19031

Dimensional datas

NPS inch	DN	A mm	B mm	H1 mm	W mm	WT kg	T N.m	NPS inch	DN	A mm	B mm	H1 mm	W mm	WT kg	T N.m
ANSI Class 900Lb															
2	50	368	49	190	650	45	296	★8	200	737	201	340	600	520	5351
3	80	381	74	208	700	78	342	★10	250	838	252	372	700	810	7683
★4	100	457	100	238	600	120	1230	★12	300	965	303	420	700	1050	13178
★6	150	610	150	312	600	255	2319	★14	350	1029	322	465	760	1386	18383

Dimensional datas

NPS inch	DN	A mm	B mm	H1 mm	W mm	WT kg	T N.m	NPS inch	DN	A mm	B mm	H1 mm	W mm	WT kg	T N.m
ANSI Class 1500Lb															
2	50	368	49	190	650	45	507	★6	150	705	144	315	600	430	3814
3	80	470	74	210	750	116	1080	★8	200	832	192	350	600	630	9380
★4	100	546	100	240	600	170	1981	★10	250	991	239	388	700	1188	14466

Note: ★ Worm-gear actuator